



880 Series Inverted Bucket Steam Traps

Cast Iron for Horizontal Installation With Integral Strainer



For Pressures to 250 psig (17 bar)...Capacities to 4,400 lb/hr (2,000 kg/hr)

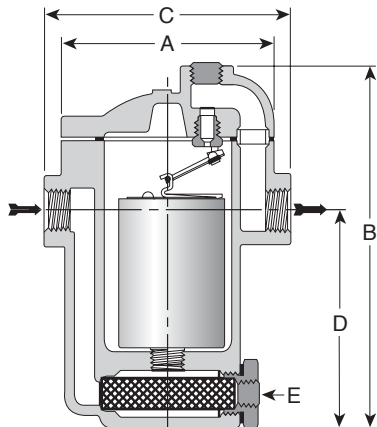

Description

The most reliable steam trap known—the inverted bucket—provides efficient condensate drainage of virtually all types of steam-using equipment. Put the inverted bucket to work in a tough cast iron package with an integral strainer, and you have the best of both worlds. Because they operate efficiently for longer periods of time, Armstrong cast iron inverted buckets add solid energy savings to lower replacement/labor costs. All Armstrong cast iron inverted bucket steam traps are repairable for even bigger maintenance savings.

A unique leverage system multiplies the force provided by the bucket to open the valve against system pressure. The mechanism is free-floating, and has no fixed pivots to create wear or friction.

Because the mechanism is located at the top of the trap, no dirt can collect on the orifice. Small particles of dirt are held in suspension until discharged by the full differential purging action when the bucket sinks, pulling the valve off the seat.

The discharge orifice is surrounded by a water seal, preventing live steam loss. Automatic air venting is provided by a small vent hole in the bucket, which provides continuous automatic air and CO₂ venting at steam temperature.

Inverted bucket traps drain continuously, although discharging intermittently, allowing no condensate backup. They are also resistant to water hammer.

Maximum Operating Conditions

Maximum allowable pressure

(vessel design): 250 psig @ 450°F (17 bar @ 232°C)

Maximum operating pressure: Model 880: 150 psig (10 bar)

Model 881-883: 250 psig (17 bar)

Connections

Screwed NPT (option BSPT)

Materials

Body: ASTM A48 Class 30

Internals: All stainless steel—304

Valve and seat: Hardened chrome steel—17-4PH

Test plug: Carbon steel

Strainer: Stainless steel—304

Options

- Stainless steel internal check valve
- Thermic vent bucket
- Scrub wire

Specification

Inverted bucket steam trap, type ... in cast iron with integral strainer, with continuous air venting at steam temperature, with free-floating stainless steel mechanism, and discharge orifice at the top of the trap.

How to Order

Specify:

- Model number
- Size and type of pipe connection
- Maximum working pressure that will be encountered or orifice size
- Any options required

For a fully detailed certified drawing, refer to CD #1000.

880 Series Side Inlet, Side Outlet Traps With Integral Strainers. Add suffix "CV" to model number for internal check valve, "T" for thermic vent bucket.

Model No.	880*		881		882		883	
	in	mm	in	mm	in	mm	in	mm
Pipe Connections	1/2,3/4	15,20	1/2,3/4,1	15,20,25	1/2,3/4	15,20	3/4,1,1-1/4	20,25,32
Test Plug	1/4	6	1/4	6	1/2	15	3/4	20
"A" (Flange Diameter)	3-3/4	95.2	3-3/4	95.2	5-5/8	142.9	7	177.8
"B" (Height)	6-1/16	154	7-1/16	179	9-3/8	244	12-3/8	314
"C" (Face-to-Face)	5	127	5	127	6-1/2	165	7-7/8	200
"D" (Bottom to \bar{Q} Inlet)	3-7/16	87.3	4-7/16	113	5-3/4	146	7-3/8	187
"E"(Blowdown Connection)	3/8	9	3/8	9	3/8	9	1/2	15
Number of Bolts	6							
Weight lb (kg)	5-1/2(2.5)		6(2.7)		15-1/2(7.0)		31 (14.1)	

*Cannot be furnished with both thermic vent bucket and check valve.





880 Series Inverted Bucket Steam Traps

Cast Iron for Horizontal Installation With Integral Strainer



For Pressures to 250 psig (17 bar)...Capacities to 4,400 lb/hr (2,000 kg/hr)

Model 880 Capacity

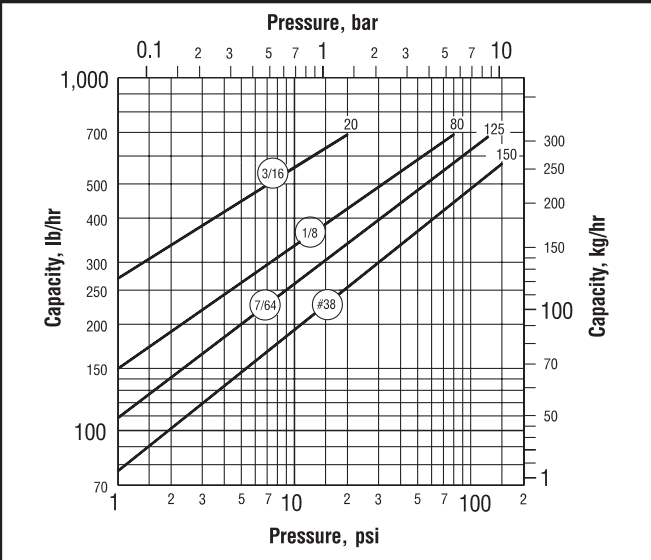

Model 881 Capacity

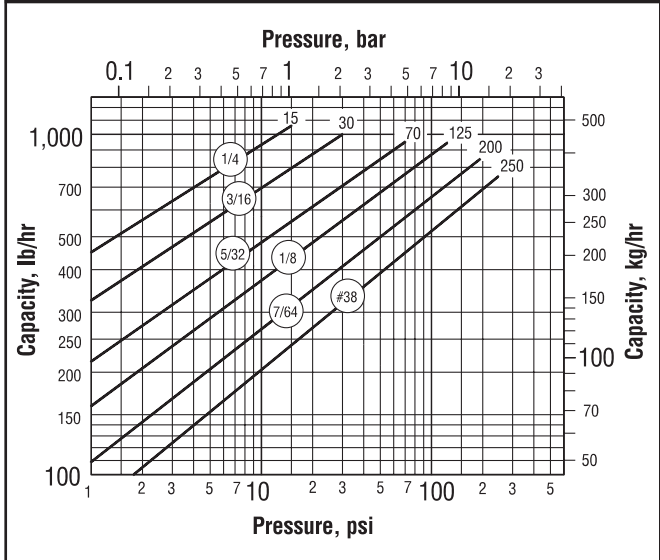

Model 882 Capacity

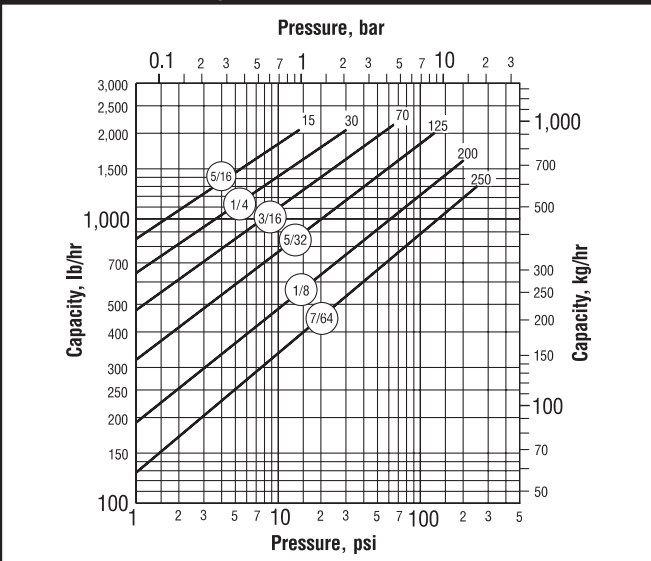

Model 883 Capacity

