



BALL VALVES RK-PROBALL

KH 1T M, 1/4" - 2", PN63



One-piece ball valve, threaded ends.

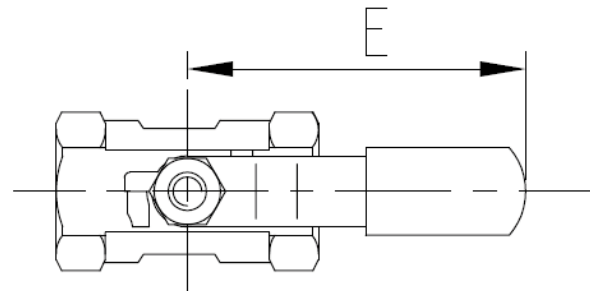
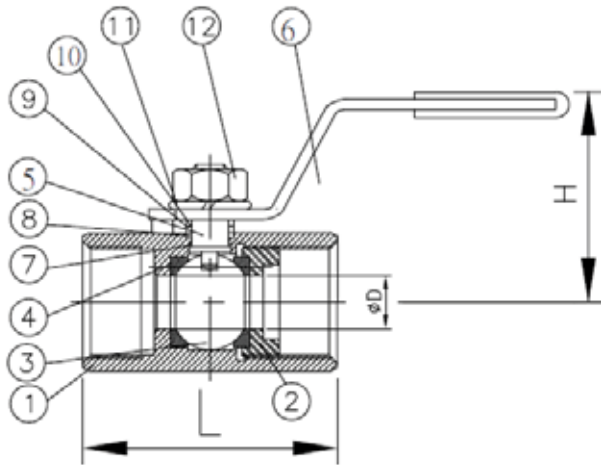

**Ball valve with threaded ends
acc. to EN 10226-1 / EN ISO 228-1
reduced bore
face to face dimensions acc. to
DIN 3202-M3**

Specification:

One-piece ball valve, threaded ends acc. to EN 10226-1/EN ISO 228-1, face to face dimensions acc. to DIN 3202-M3, reduced bore, bow-out-proof stem, body material stainless steel (1.4408), free of non ferrous metals, seat KFG, stem packing PTFE, approved by PED, inscrewed part marked with A4, nut marked with A4, high of the lever acc. to "UVV-Großchemie".

Marking: RK-Proball
Type: KH 1T M-1.4408

NO	Part	Material
1	body	1.4408
2	inscrewed part	1.4408
3	ball	1.4408
4	seat	KFG
5	stem	1.4401
6	lever	1.4301
7	stem packing	PTFE
8	thrust washer	PTFE
9	gland ring	1.4301
10	conical spring washer	1.4301
11	spring washer	1.4301
12	nut	1.4301

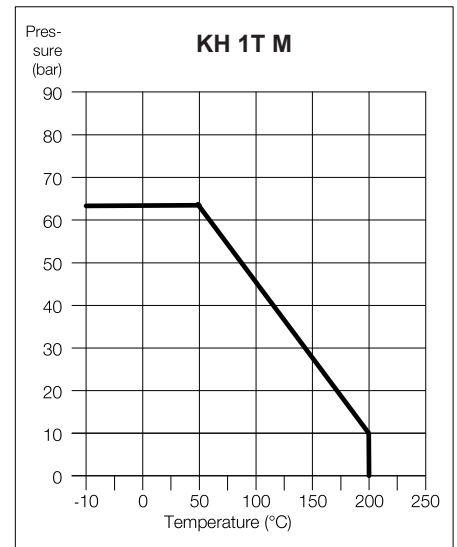

Dimensions

DN mm	DN inch	reduced bore D	dimensions (mm)			weight kg
			L	H	E	
8	1/4	5.0	50	46.5	67	0.1
10	3/8	7.0	60	49.0	67	0.1
15	1/2	9.2	75	56.5	90	0.2
20	3/4	12.5	80	60.0	90	0.3
25	1	15.0	90	67.8	112	0.4
32	1 1/4	20.0	110	69.8	112	0.7
40	1 1/2	25.0	120	74.6	132	0.8
50	2	32.0	140	79.5	132	1.3

**Ordering example:
KH 1T M, 2", PN 63, 1.4408**