



BALL VALVES INTEC

K200, DN125 - DN200, PN16/40



Two-piece ball valve, floating ball, soft seated

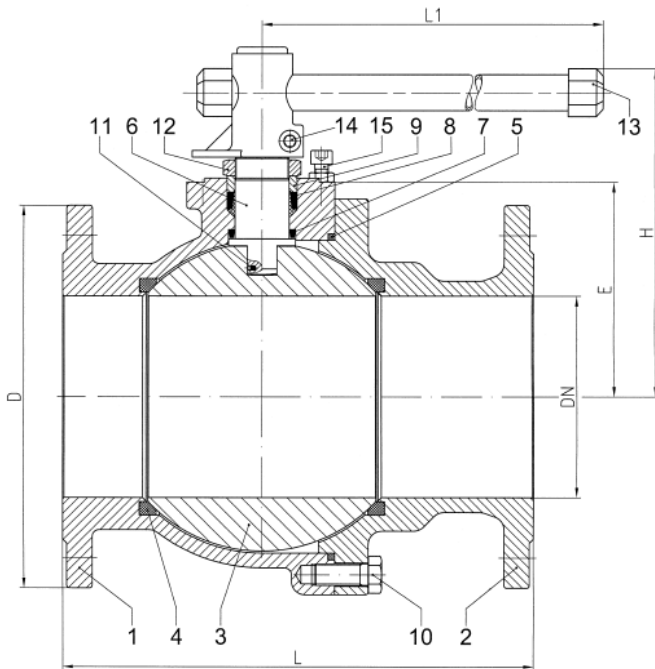

Flanged ball valve

full bore

face to face acc. to EN 558, GR. 27

flanges acc. to EN 1092

Specification:

Two-piece ball valve with flanges acc. to EN 1092, face to face dimensions acc. to EN 558, GR.27, full bore, blow-out-proof stem, vacuum-tight, body material stainless steel (1.4408) or carbon steel (1.0619), antistatic device, free of non ferrous metals, seat full chambered, stem packing Graphite/ KFGN/KFAM cone ring system dynamic loaded adjustable, top flange DIN EN ISO 5211, approved by PED, certified acc. to GERMAN clean air act VDI 2440, Fire-Safe acc. to DIN EN ISO 10497, with lever.

Marking: INTEC K200

No.	Part	Material	Material
Standard design			
1	body	1.0619	1.4408
2	cap	1.0619	1.4408
3	ball	1.4408	
4	seat	KFGN/KFM	
5	body seal	KF	
6	stem	1.4462	
7	below seal	KFGN/Graphite	
8	upper seal	KFAM/Graphite	
9	bearing	PEEK	
10	hex. screw	A4-70	
11	antistatic element	1.4401/1.4571/1.4404	
12	hex. screw selflocking	A2/1.4301	
13	lever	1.4408/1.4308/steel zincplated	
14	allen screw	A2-70	
15	stopper	A2	
Fire-Safe design			
5	combined body seal	KF-Graphite	
9	Fire-Safe seal	Graphite	
	ring	1.4571/1.4404	
	thrust washer	PEEK	

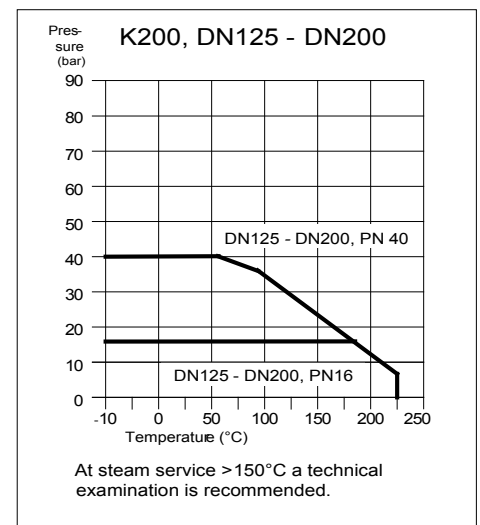

Dimensions

DN mm	PN	dimensions (mm)					top flange ISO	torque Nm**	weight kg
		H	L1	L	D	E			
125	16	263	700	325	250	164	F12	260	56
125	40	263	700	325	270	164	F12	260***	58
150	16	265	700	350	285	181	F12	286	80
150	40	265	700	350	300	181	F12	286***	85
200	16	340	1000	400	340	225	F14	442	152
200	40	340	1000	400	375	225	F14	442***	160

Ordering example:

INTEC K200, DN150, PN40, GR.27, 1.4408, Fire-Safe

** Necessary torque measured with treated water at $\Delta P = 16$ bar and room temperature.

*** PN 40 gearbox recommended.