



**BALLOSTAR®**  
KHE-CL



## Flange design (ASME)

### GENERAL FEATURES

- » 2-piece ball valve with full bore
- » Floating ball, antistatic, lockable
- » Fire Safe
- » Modular system components

### CONNECTIONS

Flange in accordance with ASME B16.5 (VIII, Xc)

### DIMENSIONS

Face-to-face dimensions in accordance with ASME B16.10

### ACCEPTANCE TESTING

- » Seat leak tightness: EN 12266-1 P12, leakage rate A
- » Tightness to atmosphere: EN 12266-1 P11
- » Strength: EN 12266-1 P10

### AUTOMATION

Flange connection in accordance with ISO 5211, allows for direct mounting of an actuator or by means of brackets. Pneumatic and electrical actuators utilizable.

### TEMPERATURE

-60 °C to +300 °C (see pT diagram)

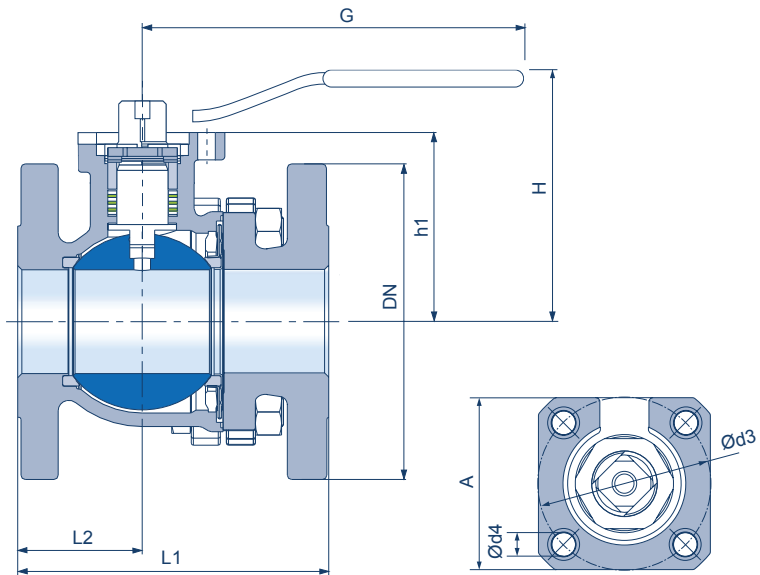

## KHE-CL VARIANTS

### PRESSURE RANGE CLASS 150

Material: Steel casting 1.0619

(Material code VIII)

Stainless steel casting 1.4408

(Material code Xc)

### PRESSURE RANGE CLASS 300

Material: Steel casting 1.0619

(Material code VIII)

Stainless steel casting 1.4408

(Material code Xc)

NPS	Dimensions					lz*	Class		Mounting flange for actuator				Weight kg
	L1	L2	H	G	h1		VIII	Xc	ISO	A	Ød3	Ød4	
1/2"	108	43	81	130	35	4	150	150	F04	42	42	5.8	1.6
3/4"	117	42	95	160	46	4	150	150	F04	42	42	5.8	2.5
1"	127	47	98	160	50	4	150	150	F04	42	42	5.8	3.3
1 1/2"	165	64	114	250	72	4	150	150	F05	50	50	7	7.0
2"	178	60	131	315	90	4	150	150	F07	70	70	10	11.2
2 1/2"	190	66	141	315	100	4	150	150	F07	0	70	10	17.1
3"	203	83	163	500	121	4	150	150	F10	102	102	12	24.3
4"	229	83	176	500	135	8	150	150	F10	102	102	12	34.8
6"	394	184	234	650	195	8	150	150	F12	125	125	15	69.4
8"	457	222	300	650	236	8	150	150	F12	140	125	15	121
1/2"	140	70	81	130	35	4	300	300	F04	42	42	5.8	2.3
3/4"	152	65	95	160	46	4	300	300	F04	42	42	5.8	3.8
1"	165	75	98	160	50	4	300	300	F04	42	42	5.8	4.7
1 1/2"	190	75	114	250	72	4	300	300	F05	50	50	7	9.7
2"	216	90	131	315	90	8	300	300	F07	70	70	10	13.4
2 1/2"	241	111	141	315	100	8	300	300	F07	0	70	10	19.8
3"	282	127	163	500	121	8	300	300	F10	102	102	12	30.9
4"	305	135	176	500	135	8	300	300	F10	102	102	12	46.4

\* Number of bores



: @ALPHAGROUP



: 0-2792-9333



: www.alphagroup.co.th