

SAFETY RELIEF VALVE

Type AL-80

YOSHITAKE



Lift type

Safety relief valve

Closed type

FEATURES

1. Versatile type, compatible with fluids such as steam, air, water, and oil.
2. Achieved the highest performance by segmentalize the pressure range and finished by ultra-precision technique.
3. The trim parts (valve and valve seat) and adjusting spring are made of stainless steel. Used for the trim parts is SCS14A (equivalent to SUS316) with outstanding corrosion resistance.
4. Closed structure prevents fluid leakage to outside.

SPECIFICATIONS

Structure	Closed type	
Application	Steam, Air, Hot and Cold water, Oil, Other non-dangerous fluids	
Working pressure	0.05-1.0 MPa	
Working temperature	5-220°C *1	
Material	Body	Bronze
	Spring case	Bronze
	Valve, Valve seat	Stainless steel (SCS14A)
	Adjusting spring	Stainless steel
Connection	JIS Rc screwed	

*1 The maximum temperature is 150°C when using for water, oil, or other liquids.

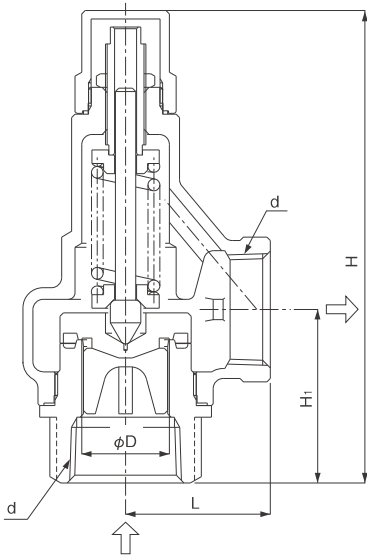

DIMENSIONS AND WEIGHTS

Nominal size	Dimension (mm)					Flow area πD^2 (mm ²)	Weight (kg)
	d	D	L	H ₁	H		
15A	Rc 1/2	16	34	40	128	20.1	0.7
20A	Rc 3/4	21	38	43	128.5	34.6	0.8
25A	Rc 1	26	43	51.5	144.5	53.0	1.1
32A	Rc 1-1/4	33	50	61.5	181.5	93.3	1.8
40A	Rc 1-1/2	41	60	60	205	135.2	2.8
50A	Rc 2	51	75	76	245.5	208.2	4.7

CERTIFIED CAPACITY TABLE

AL-80 for steam (saturation temperature) <Pressure vessel structure standard>

(kg/h)

Pressure MPa \ Nominal size	0.05	0.1	0.2	0.3	0.4	0.5	0.6	0.7	0.8	0.9	1.0
15A	15	20	29	40	50	60	70	80	90	100	109
20A	27	35	51	69	87	104	121	138	155	172	189
25A	42	54	78	105	133	159	186	212	237	263	289
32A	70	91	132	178	224	268	313	356	400	443	487
40A	105	136	198	266	335	402	468	534	599	664	729
50A	163	211	306	411	518	621	723	824	924	1025	1126

AL-80 for air (20°C) <Pressure vessel structure standard>

(kg/h)

Pressure MPa \ Nominal size	0.05	0.1	0.2	0.3	0.4	0.5	0.6	0.7	0.8	0.9	1.0
15A	25	33	48	65	81	98	114	131	147	164	181
20A	44	57	83	111	140	169	197	226	254	283	311
25A	67	87	127	171	215	258	302	346	390	433	477
32A	113	147	214	288	362	435	509	582	656	730	803
40A	169	221	321	431	542	652	762	872	982	1093	1203
50A	262	341	496	666	836	1006	1176	1346	1516	1687	1857

AL-80 for water (accumulation: 25%) <Yoshitake standard>

(m³/h)

Pressure MPa \ Nominal size	0.05	0.1	0.2	0.3	0.4	0.5	0.6	0.7	0.8	0.9	1.0
15A	0.4	0.5	0.9	1.1	1.3	1.5	1.6	1.8	1.9	2.0	2.1
20A	0.6	0.9	1.6	2.0	2.3	2.6	2.8	3.1	3.3	3.5	3.7
25A	1.0	1.5	2.5	3.1	3.6	4.0	4.4	4.7	5.1	5.4	5.7
32A	1.8	2.6	4.5	5.5	6.3	7.1	7.8	8.4	9.0	9.5	10.0
40A	2.7	3.8	6.5	7.9	9.2	10.3	11.3	12.2	13.0	13.8	14.6
50A	4.1	5.9	10.0	12.3	14.2	15.9	17.4	18.8	20.1	21.3	22.4

