

# BUTTERFLY VALVE

## Type BL301N / BG301N



### General Features

Wafer butterfly valve of which retentive elastomer line can be replaced on site without extra tools. Complete, permanent and continuous leak-tightness provided by spherical contact between the disc and the liner and shaft sealing provided by flatly raised seat surface and polished disc-hub area.

Specifications	
<b>Standard</b>	according to ISO5752-BS5155-MSS SP67- API 609
<b>Product range</b>	40 mm up to 1000mm (1.1/2"~40")
<b>Pressure range</b>	designed for maximum working pressure of 16bar (240Psi)
<b>Flange connections</b>	The shape of valve body has been so designed as to allow flange bolt alignment onto following standards. Wafer type valve has been successfully developed to fit multi functional application onto either connection standard in the same configuration, mainly Between Flange ISO PN 6, 10, 16, 20 ANSI B16-5 CL. 150 JIS B2210 5K, 10K, 16K and 20K
<b>Face to face dimensions</b>	in accordance with ISO 5752, BS 5155, MSS SP67 and API609
<b>Actuator connection</b>	valves can be fitted with any 1/4 turn actuator equipped with a mounting plate meeting the standard ISO5211
<b>Test Inspection</b>	DK valves are guaranteed to seal perfectly (no visible leakage) in both flow directions. The test conforms to API598.
<b>Body test</b>	1.5 times the maximum working pressure with water. The test is performed on the assembled valve with the disc in half open position.
<b>Seat and shaft seal test</b>	1.1 times the maximum working pressure. The shaft seal test and inspection is conducted simultaneously with seat test.

### Leak-tightness at line stream

A perfect zero leakage seal at bi-direction is obtained by the compression of the inner between the valve body and the edge of the disc. A perfect zero leakage seal is provide by means of flatted liner area around both up and down shaft passages and the spherically machined disc.

- Heavy duty top bushing absorbs side thrust load
- Mounting plate in accordance with ISO standard

#### • Sealing

Hub seal provided by preloaded contact between flatted seat surface and spherically machined and polished disc-hub area for positive sealing at all disc positions.

#### • Disc edge

Spherically machined and polished disc edge provide full concentric sealing, lower lever torques, seat life and positive shut-off closed at both directions.

#### • Liner

Retained resilient seat to valve enable easy replacement and isolates the body and stem from the flow. Special design of built-in O-ring provides positive flange sealing with no pipeline gasket required.

#### • Piping guide rib

Flange bolt alignment and installation suit for multi-national standard such as JIS, DIN, ANSI and BS flange standard.

#### • Body

Face to face dimension in accordance with API and ISO standard

#### • Thru-shaft

Provide high strength and absolutely BOLTED disc control and gives minimum obstruction to flow

Materials		
Part	Materials	
<b>Body</b>	*Cast iron Ductile iron Carbon steel Stainless steel Bronze	ASTM A 126 Cl. B ASTM A 536 Gr 65-45-12 ASTM A 216 WCB ASTM A 351 Gr CF8-CF8M ASTM B 62
<b>Disc</b>	Ductile iron *Stainless steel Aluminum bronze Coated	ASTM A 536 Gr 65-45-12 ASTM A 351 Gr CF8-*CF8M ASTM B 148 Cl. C95500 EPDM, Viton, Buna-N, etc
<b>Stem</b>	Stainless steel Stainless steel *Stainless steel Stainless steel K-Monel	ASTM A 276 304 ASTM A 276 410 ASTM A 276 316 17-4PH ASTM A 564 Type 630 ASTM B 164
<b>Seat</b>	Elastomer *EPDM NBR *Viton Silicon Neoprene	Working temperature - 15°C ~ + 110°C - 10°C ~ + 80°C - 20°C ~ + 150°C - 20°C ~ + 140°C - 10°C ~ + 90°C
<b>Packing</b>	EPDM NBR Viton	
<b>Gland</b>	PP	

Note \* Standard Stock

# BUTTERFLY VALVE

Type BL301N / BG301N

 Dong Kwang Valves

ALPHA GROUP

## Overall Dimensions

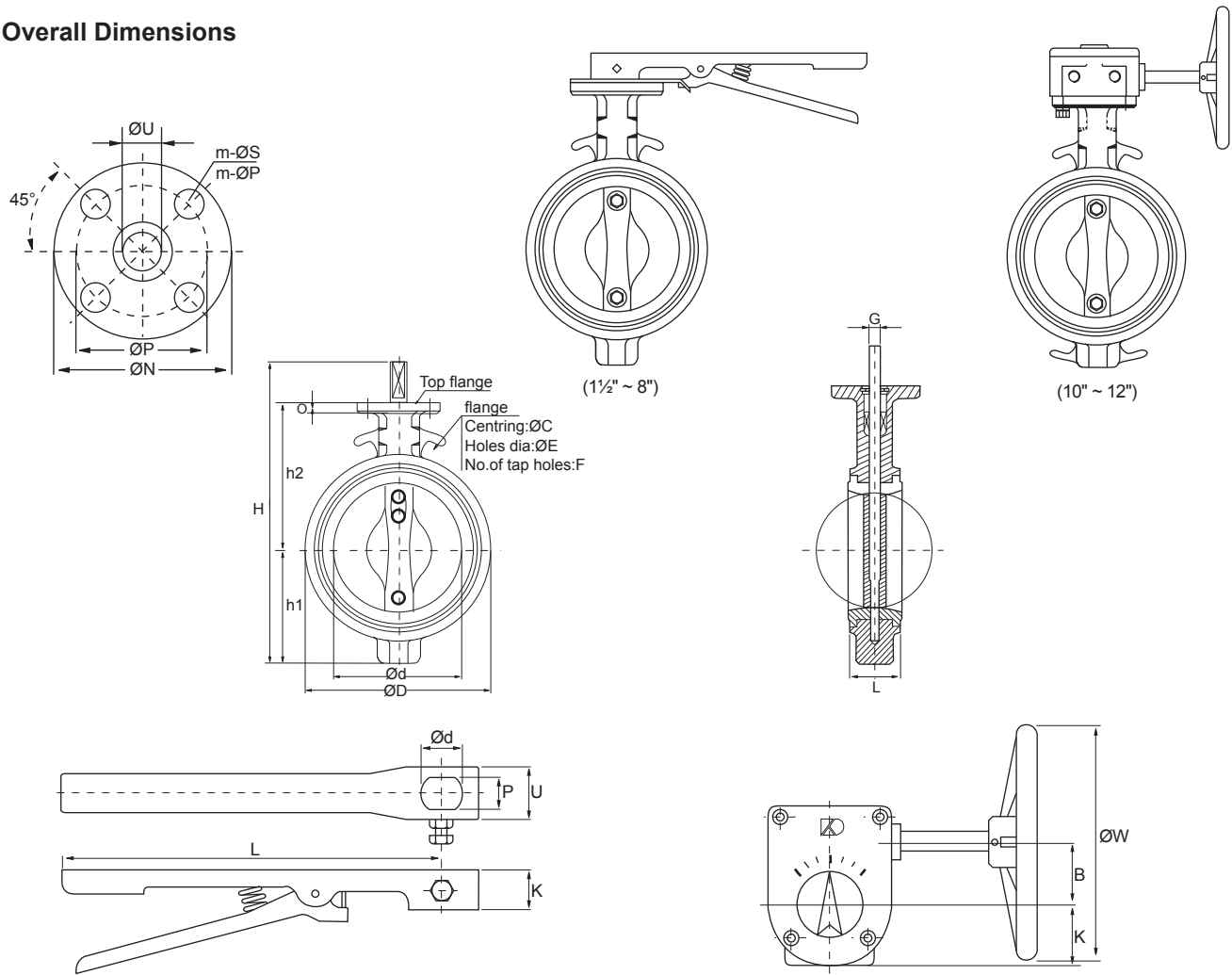

Size		ØD	Ød	L	H	h1	h2	Stem		Top flange to ISO 5211				O	WT (kg)	
Inch	mm							ØU	G	Type	ØN	ØP	m			ØS
1.1/2"	40	86	40	33	205	58	124	10	8	F07	90	70	4	9	10	3.1
2"	50	105	52	43	227	66.5	130.5	14	10	F07	90	70	4	9	11	3.7
2.1/2"	65	114	65	46	241	71	140	14	10	F07	90	70	4	9	11	4
3"	80	129	80	46	263	83	150	14	10	F07	90	70	4	9	11	4.4
4"	100	155	100	52	290	95	163	16	12	F07	90	70	4	9	11	5.9
5"	125	180	125	56	319	110	178	19	15	F07	90	70	4	9	12	8.9
6"	150	207	150	56	347	124	191	19	15	F07	90	70	4	9	12	9
8"	200	260	198	60	433	163	238	22	18	F07	90	70	4	9	13	11
10"	250	331	248	68	546	227	285	28	20	F10	125	102	4	12	15	20
12"	300	377	298	78	601	252	315	28	20	F10	125	102	4	12	15	31.5
14"	350	416	327	78	675	271	324	32	19.5	F10	125	102	4	12	20	43
16"	400	475	387	102	817	343	369	35	-	F14	175	140	4	18	23	63.5

Dimensions														
Hand Level	Size	T	U	P	L	Ød	Gear Operated	Size	B	K	P	ØW	Ratio	
Steel Level or Al. di-casting Level	1 1/2"	28	38	8	207	10	Worm gear box	8"	49	53	160	190	28:1	
	2"-3"	28	38	10	207	14		10"-12"	65	65	210	250	36:1	
	4"	28	38	12	267	16		14"	65	65	270	300	40:1	
	5"-8"	28	38	15	267	19		16"	92	95	330	400	40:1	
									18"-24"	110	118	330	400	46:1