

BALL CHECK VALVE

Type 418

Cast iron ball type PN 10 DN 50 - 200

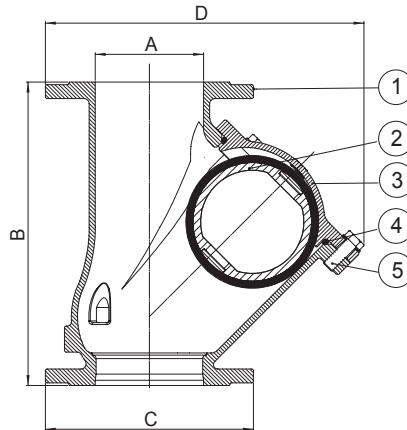

Applications and special features

- Vertical ascending and horizontal position (position the ball housing above the axis of the pipe)
- Minimum head loss
- Silent, robust
- Non incrustating materials
- Closing system : ball lifted up by the liquid and guided to a lateral housing completely out of the way
- Sealing guaranteed by the coating of the ball.
- Maximum Temperature : 80 °C

Working principle

DN		Opening pressure in mm/CE		Kv	ζ
inch	mm	↑	↔	m ³ /H	
2	50	25	near 0	71.5	1.95
2 ^{1/2}	65	30		171.5	0.97
3	80	160		217.5	1.38
4	100	160		319	1.57
5	125	170			
6	150	200			
8	200	250			

Dimensions

DN	B	C	D	Weight	
“	A mm	mm	mm	kg	
2	50	200	165	173	5.5
2 ^{1/2}	65	240	185	214	9.1
3	80	260	200	252	13.3
4	100	300	220	289	20.9
5	125	350	250	368	27.5
6	150	400	285	424	35.7
8	200	500	340	509	63.7

Spare parts list and materials

Nb	Description	Materials	EURO	ANSI
1	Casing	Ductile iron + epoxy	EN-GJS-400.15	ASTM A 536 60-40-18
2	Ball DN 50 up to 100	Aluminium + NBR		
	DN 125 up to 200	Cast iron + NBR	EN-GJL-250	ASTM A 48 35 B
3	Cap	Ductile iron + epoxy	EN-GJS-400.15	ASTM A 536 60-40-18
4	Seal	NBR		
5	Screw	Stainless steel	X5Cr-Ni18-10	AISI 304

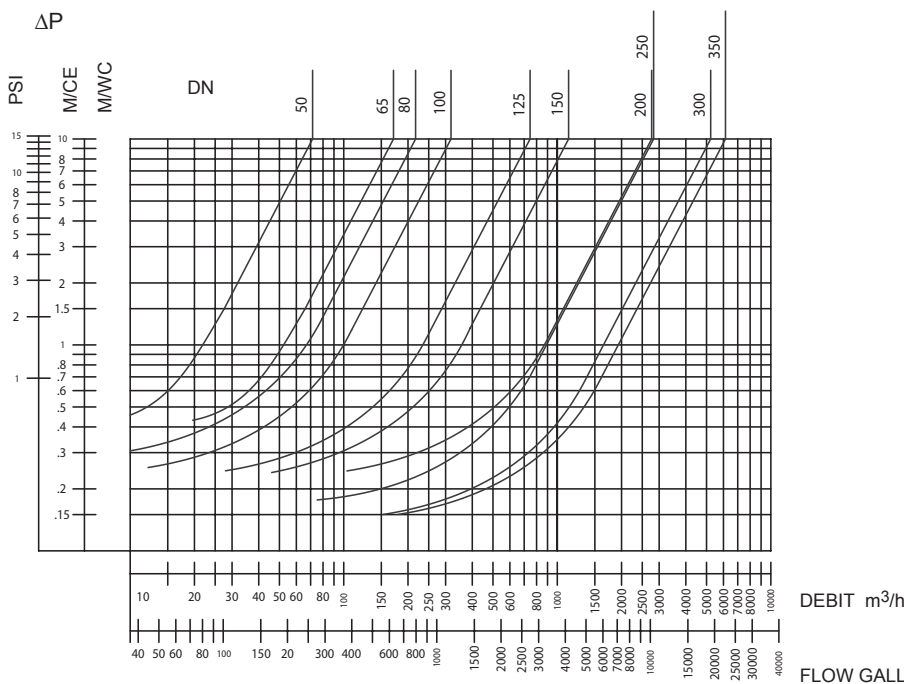

Direction for use :

- Solid line : Valve completely open
- Dotted line : opening stage of valve