

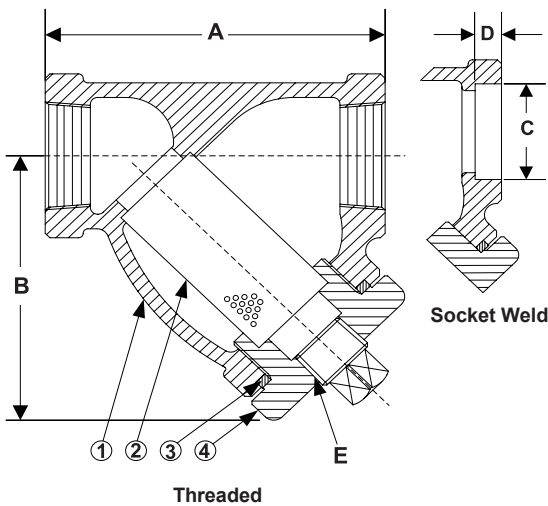

Cast Carbon Steel Y-Strainer



Applications

Steam, water, oil or gas where protection from foreign matter in a pipeline is required.

Working Pressures – Non Shock

Nom. Rating	Media	1/4" to 3"	8 mm to 80 mm
600# (Threaded & Socket Weld)	STEAM	600 PSI @ 838°F	4138 KPa @ 448°C
	W.O.G.	1480 PSI @ 100°F	10208 KPa @ 38°C

Materials List

Item	Description	Material
1*	Body	Cast Carbon Steel (ASTM A 216, GRADE WCB)
2	Screen	Stainless Steel (304)
3	Gasket	Spiral Wound Stainless Steel (304)
4	Cap	Cast Carbon Steel (ASTM A 216, GRADE WCB)

Optional: Blow-off Plug, Carbon Steel (ASTM A 105)

*Optional Body Materials Available in LCB, WC6, and WC9.

Total Screen AREA

Size	(in ²)	Size	(in ²)
1/2"	2.75	1-1/2"	16.33
3/4"	4.71	2"	27.04
1"	10.08	2-1/2"	78.14
1-1/4"	12.79	3"	78.14

Dimensions

Size		A		B		C		D		E		Weights	
in	mm	in	mm	in	mm	in	mm	in	mm	in	mm	lbs	kgs
1/4"	8	2-15/16	75	2-7/16	62	0.555	14	3/8	10	1/4	8	3	1
3/8"	10	2-15/16	75	2-7/16	62	0.690	18	3/8	10	1/4	8	3	1
1/2"	15	2-15/16	75	2-7/16	62	0.855	22	3/8	10	1/4	8	3	1
3/4"	20	3-11/16	94	3	76	1.065	27	1/2	13	3/8	10	5	2
1"	25	4-9/16	116	4-5/16	110	1.330	34	1/2	13	3/8	10	6	3
1-1/4"	32	4-15/16	125	4-3/16	106	1.675	43	1/2	13	3/4	20	8	4
1-1/2"	40	5-9/16	141	4-11/16	119	1.915	49	1/2	13	3/4	20	10	5
2"	50	6-15/16	176	6-1/4	159	2.406	61	5/8	16	1	25	16	7
2-1/2"	65	12	305	9-3/8	238	2.906	74	5/8	16	1-1/4	32	43	20
3"	80	12	305	9-3/8	238	3.535	90	5/8	16	1-1/4	32	43	20

Certified dimensional drawings are available upon request

†This table reflects only the nearest metric equivalents.

