

Strainer

Type JST-YT11 (FST-S)

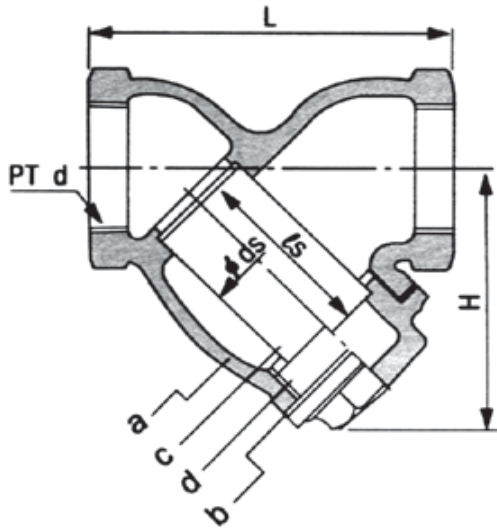

JST-YT11 (FST-S)

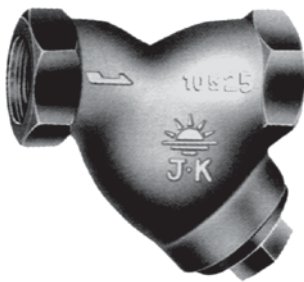
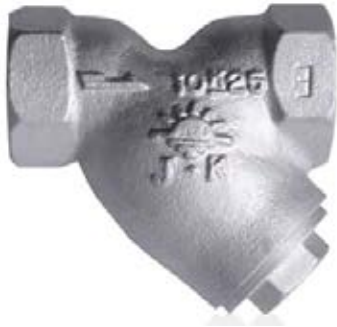

Materials

No	Part Model	Material
a	Body	Cast iron
b	Cap	Forged brass
c	Screen	Stainless steel (For reference see filtering metal)
d	Gasket	Non-Asbestos
Connection		PT Screwed
Working pressure		Max. 10kgf/cm ² {1.0MPa}
Working temperature		Max. 200°C
Working fluid		Air, steam, water and/ or noncorrosive media

Mash (Stainless Steel)

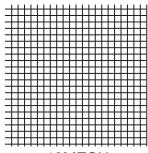
213 mm Wire dia.  40MESH (44% open area)	Mesh	P	S.W.G	Wire dia.	R(%)
	40	40	35	0.2134	44.1
60	60	38	0.1524	41.2	
80	80	41	0.1118	42.0	
100	100	42	0.1016	36.0	

Dimensions (mm)

Model	Part	Size mm(inch)					
		15(1/2")	20(3/4")	25(1")	32(1 1/4")	40(1 1/2")	50(2")
FST-S	d	PT 1/2"	PT 3/4"	PT 1 1/4"	PT 1 1/4"	PT 1 1/2"	PT 2"
	l	80	94	114	140	152	174
	h	60	75	85	95	105	115
	ds	23	28	38	46	51	59
	ts	34.3	49	63	66	75.5	87.5
	Wt(kg)	0.6	0.9	1.4	2.1	2.8	4.2

