

CAST STEEL SWING CHECK VALVES

CLASS 150

Figure No. Type of Ends
5341RF Flanged Raised Face

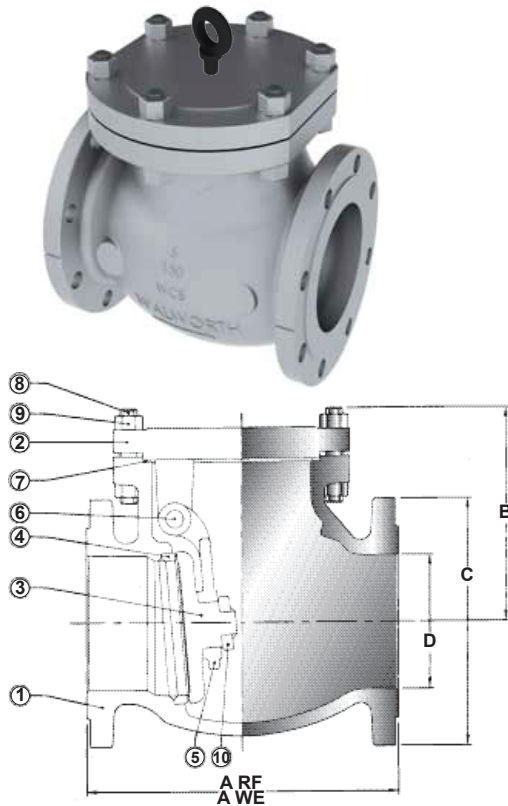

Standard Material Specifications

No.	Description	Materials
1	Body	ASTM A216 GR WCB
2	Cover	ASTM A216 GR WCB
3	Disc	ASTM A216 GR WCB + 13% Cr.
4	Seat Ring	ASTM A515 GR 70 + ST6
5	Hanger	ASTM A216 GR WCB
6	Hanger Pin	ASTM A276 Type 410
7	Cover Gasket	Graphite/Stainless 316
8	Cover Stud	ASTM A193 GR B7
9	Cover Stud Nut	ASTM A194 GR 2H
10	Disc Nut	Alloy Steel
*11	Body Plug +	Alloy Steel
*12	Identification Plate	Stainless Steel

* Not Shown
 + 14" and larger

Dimensions

D Nominal Diameter	mm inch	50 2	65 2 1/2	80 3	100 4	150 6	200 8	250 10	300 12	350 14	400 16	450 15	500 20	600 24
A	mm.	203.2	215.9	241.3	292.1	355.6	495.3	622.3	698.5	787.4	762	838.2	914.4	1066.8
B	mm.	134	164	162	205	238	290	349	381	457	502	573	606	702
C	mm.	152.4	177.8	190.5	228.6	279.4	342.9	406.4	482.6	533.4	596.9	635	698.5	812.8
Weight	kg.	15	23	26	36	77	152	242	350	527	650	950	1150	1596

Trim

Trim		Internal Parts		
API	Walworth	Seat Ring	Gate (Disc)	Stem Hanger Pin Bonnet Bushing
8	*UT	Stellite No. 6	13% Cr. (SS 410)	13% Cr. (SS 410)
5	HF	Stellite No. 6	Stellite No. 6	13% Cr. (SS 410)

*UT-Trim (Universal Trim)

Test Pressures

For valves having flanges or butt welding ends to ANSI Class 150 Standards.

	shell Hydrostatic	Seat* Hydrostatic
lbf/in ²	450	315
MPa	3.1	2.2

*Seat leakage rate: All valves meet BS 6755 Part 1 leakage rate A (No visible leakage for duration of test).

Pressure - Temperature Ratings

°F Temperature °C		MAXIMUM ALLOWABLE NON-SHOCK WORKING PRESSURE IN PSIG BYCLASS					
		150	300	400	600	900	1500
-20 to 100	-29 to 38	285	740	990	1,480	2,220	3,705
200	93	260	675	900	1,350	2,025	3,375
300	149	230	655	875	1,315	1,970	3,280
400	204	200	635	845	1,270	1,900	3,170
500	260	170	600	800	1,200	1,795	2,995
600	316	140	550	730	1,095	1,640	2,735
650	343	125	535	715	1,075	1,610	2,685
700	371	110	535	710	1,065	1,600	2,665
750	399	95	505	670	1,010	1,510	2,520
800	427	80	410	550	825	1,235	2,060
850	454	65	270	355	535	805	1,340
900	482	50	170	230	345	515	860
950	510	35	105	140	205	310	515
1000	538	20	50	70	105	155	260

For prolonged usage at temperatures above 800°F (427°C), consideration should be given to the possibility of graphite formation in Carbon Steel.

CAST STEEL SWING CHECK VALVES

CLASS 300



Figure No. Type of Ends
5344RF Flanged Raised Face

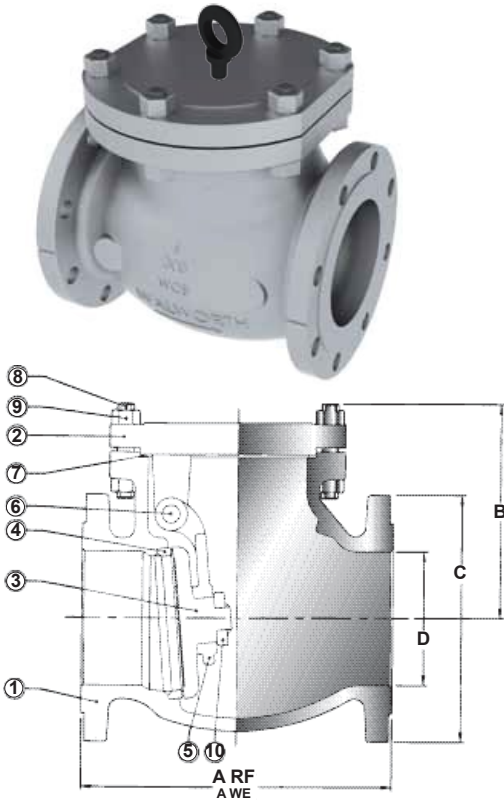

Standard Material Specifications

No.	Description	Materials
1	Body	ASTM A216 GR WCB
2	Cover	ASTM A216 GR WCB
3	Disc	ASTM A216 GR WCB + 13% Cr.
4	Seat Ring	ASTM A515 GR 70 + ST6
5	Hanger	ASTM A216 GR WCB
6	Hanger Pin	ASTM A276 Type 410
7	Cover Gasket	Spiral Stainless 304/Graphite
8	Cover Stud	ASTM A193 GR B7
9	Cover Stud Nut	ASTM A194 GR 2H
10	Disc Nut	Alloy Steel
*11	Body Plug +	Alloy Steel
*12	Identification Plate	Stainless Steel

* Not Shown
+ 14" and larger

Dimensions

D Nominal Diameter	mm inch	50	65	80	100	150	200	250	300	350	400	450	500	600
		2	2 1/2	3	4	6	8	10	12	14	16	15	20	24
A	mm.	267	292	318	357	445	533	622	711	838	864	978	1016	1346
B	mm.	144	179	184	221	260	348	395	456	524	567	597	648	797
C	mm.	165	191	219	254	318	381	445	521	584	648	711	775	914
Weight	kg.	24	38	38	52	118	209	352	542	770	862	1200	1650	2260

Trim

Trim		Internal Parts		
API	Walworth	Seat Ring	Gate (Disc)	Stem Hanger Pin Bonnet Bushing
8	*UT	Stellite No. 6	13% Cr. (SS 410)	13% Cr. (SS 410)
5	HF	Stellite No. 6	Stellite No. 6	13% Cr. (SS 410)

*UT-Trim (Universal Trim)

Test Pressures

For valves having flanges or butt welding ends to ANSI Class 300 Standards.

	shell Hydrostatic	Seat* Hydrostatic
lb/in ²	1125	825
MPa	7.7	5.7

*Seat leakage rate: All valves meet BS 6755 Part 1 leakage rate A (No visible leakage for duration of test).

Pressure - Temperature Ratings

°F Temperature °C		MAXIMUM ALLOWABLE NON-SHOCK WORKING PRESSURE IN PSIG BYCLASS					
		150	300	400	600	900	1500
-20 to 100	-29 to 38	285	740	990	1,480	2,220	3,705
200	93	260	675	900	1,350	2,025	3,375
300	149	230	655	875	1,315	1,970	3,280
400	204	200	635	845	1,270	1,900	3,170
500	260	170	600	800	1,200	1,795	2,995
600	316	140	550	730	1,095	1,640	2,735
650	343	125	535	715	1,075	1,610	2,685
700	371	110	535	710	1,065	1,600	2,665
750	399	95	505	670	1,010	1,510	2,520
800	427	80	410	550	825	1,235	2,060
850	454	65	270	355	535	805	1,340
900	482	50	170	230	345	515	860
950	510	35	105	140	205	310	515
1000	538	20	50	70	105	155	260

For prolonged usage at temperatures above 800°F (427°C), consideration should be given to the possibility of graphite formation in Carbon Steel.

CAST STEEL SWING CHECK VALVES

CLASS 600

Figure No. Type of Ends
5350RF Flanged Raised Face

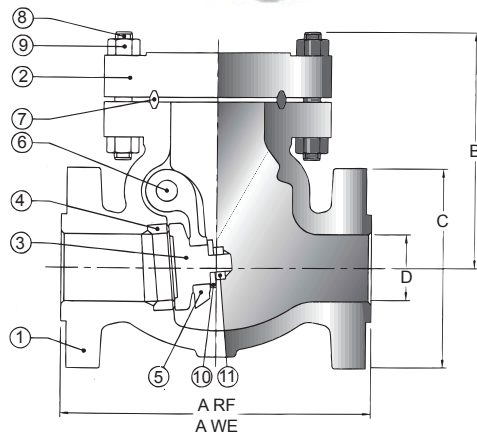

Standard Material Specifications		
No.	Description	Materials
1	Body	ASTM A216 GR WCB
2	Cover	ASTM A216 GR WCB
3	Disc	ASTM A216 GR WCB + 13% Cr.
4	Seat Ring	ASTM A515 GR 70 + ST6
5	Hanger	ASTM A216 GR WCB
6	Hanger Pin	ASTM A276 Type 410
7	Cover Gasket	ASTM A108 GR 1010
8	Cover Stud	ASTM A193 GR B7
9	Cover Stud Nut	ASTM A194 GR 2H
10	Disc Washer	ASTM A276 Type 410
11	Disc Nut	Alloy Steel
*12	Body Plug	Alloy Steel
*13	Identification Plate	Stainless Steel

* Not Shown

Dimensions														
D Nominal Diameter	mm inch	50	65	80	100	150	200	250	300	350	400	450	500	600
		2	2 1/2	3	4	6	8	10	12	14	16	15	20	24
A	mm.	292.1	330.2	355.6	431.8	558.8	660.4	787.4	838.2	889	990.6	1092.2	1193.8	1397
B	mm.	175	190	219	262	344	422	486	536	687	643	717	840	817
C	mm.	165.1	190.5	209.6	273	355.6	419.1	508	558.8	603.2	685.8	743	812.8	939.8
Weight	kg.	36	47	62	119	248	528	700	1000	1250	1724	2400	3000	3450

Trim				
Trim		Internal Parts		
API	Walworth	Seat Ring	Gate (Disc)	Stem Hanger Pin Bonnet Bushing
8	*UT	Stellite No. 6	13% Cr. (SS 410)	13% Cr. (SS 410)
5	HF	Stellite No. 6	Stellite No. 6	13% Cr. (SS 410)

*UT-Trim (Universal Trim)

Test Pressures

For valves having flanges or butt welding ends to ANSI Class 600 Standards.

	shell Hydrostatic	Seat* Hydrostatic
lb/in ²	2250	1650
MPa	15.4	11.3

*Seat leakage rate: All valves meet BS 6755 Part 1 leakage rate A (No visible leakage for duration of test).

°F Temperature °C		MAXIMUM ALLOWABLE NON-SHOCK WORKING PRESSURE IN PSIG BYCLASS					
		150	300	400	600	900	1500
-20 to 100	-29 to 38	285	740	990	1,480	2,220	3,705
200	93	260	675	900	1,350	2,025	3,375
300	149	230	655	875	1,315	1,970	3,280
400	204	200	635	845	1,270	1,900	3,170
500	260	170	600	800	1,200	1,795	2,995
600	316	140	550	730	1,095	1,640	2,735
650	343	125	535	715	1,075	1,610	2,685
700	371	110	535	710	1,065	1,600	2,665
750	399	95	505	670	1,010	1,510	2,520
800	427	80	410	550	825	1,235	2,060
850	454	65	270	355	535	805	1,340
900	482	50	170	230	345	515	860
950	510	35	105	140	205	310	515
1000	538	20	50	70	105	155	260

For prolonged usage at temperatures above 800°F (427°C), consideration should be given to the possibility of graphite formation in Carbon Steel.