

CAST STEEL GATE VALVES

CLASS 150

Figure No. Type of Ends
5202RF Flanged Raised Face

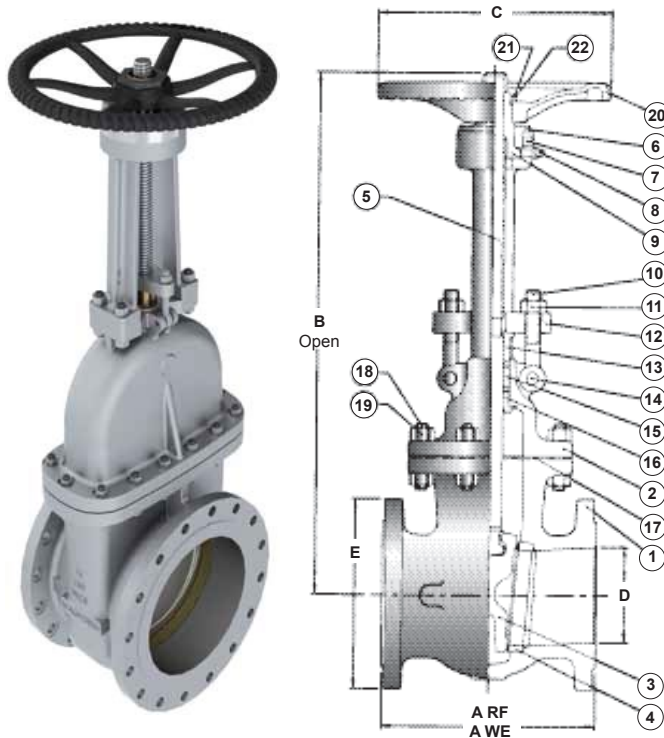

Standard Material Specifications

No.	Description	Materials
1	Body	ASTM A216 GR WCB
2	Bonnet	ASTM A216 GR WCB
3	Wedge Gate	ASTM A 216 GR WCB + 13% Cr
4	Seat Ring	ASTM A 515 GR 70 + ST6
5	Stem	ASTM A276 Type 410
6	Yoke	ASTM A216 GR WCB
7	Stem Nut Retainer	ASTM A 36
8	Grease Fitting	Commercial Steel
9	Stem Nut	ASTM B 148 UNS C95600
10	Eyebolt	Alloy Steel
11	Eyebolt Nut	ASTM A 307
12	Gland	ASTM A515 GR 70
13	Packing Bushing	ASTM A 108 GR 1020
14	Eyebolt Pin	Alloy Steel
15	Stem Packing	Graphite
16	Bonnet Bushing	ASTM A 276 Type 410
17	Bonnet Gasket	Graphite/Stainless 316
18	Bonnet Stud	ASTM A 193 GR B7
19	Bonnet Stud Nut	ASTM A 194 GR 2H
20	Handwheel	ASTM A 197
21	Handwheel Nut	ASTM A 108 GR 1020
22	Set Screw	Alloy Steel
23	Yoke Stud	Alloy Steel
24	Yoke Stud Nut	ASTM A 307
25	Retainer Bolt	Alloy Steel
26	Retainer Bolt Nut	ASTM A 307
*27	Identification Plate	Stainless Steel

* Not Shown

*The above part lists're for size 8" up

Dimensions

D Nominal Diameter	mm	50	65	80	100	150	200	250	300	350	400
	inch	2	2 1/2	3	4	6	8	10	12	14	16
A	mm.	177.8	190.5	203.2	228.6	266.7	292.1	330.2	355.6	381	406
B	mm.	477.8	482.6	552.5	674.7	830.3	1062	1253	1461	1661	1835
C	mm.	203.2	177.8	254	254	304.8	355.6	406.4	508	559	660
E	mm.	152.4	177.8	190.5	228.6	279.4	343	406	483	533	597
Weight	kg.	19	30.8	32	47	73	133	200	270	492	598

Trim

Trim		Internal Parts		
API	Walworth	Seat Ring	Gate (Disc)	Stem Hanger Pin Bonnet Bushing
8	*UT	Stellite No. 6	13% Cr. (SS 410)	13% Cr. (SS 410)
5	HF	Stellite No. 6	Stellite No. 6	13% Cr. (SS 410)

*UT-Trim (Universal Trim)

Test Pressures

For valves having flanges or butt welding ends to ANSI Class 150 Standards.

	shell Hydrostatic	Seat* Hydrostatic	Seat*Air under Water
lbf/in ²	450	315	100
MPa	3.1	2.2	.7

*Seat leakage rate: All valves meet BS 6755 Part 1 leakage rate A (No visible leakage for duration of test).

Pressure - Temperature Ratings

°F Temperature °C		MAXIMUM ALLOWABLE NON-SHOCK WORKING PRESSURE IN PSIG BYCLASS					
		150	300	400	600	900	1500
-20 to 100	-29 to 38	285	740	990	1,480	2,220	3,705
200	93	260	675	900	1,350	2,025	3,375
300	149	230	655	875	1,315	1,970	3,280
400	204	200	635	845	1,270	1,900	3,170
500	260	170	600	800	1,200	1,795	2,995
600	316	140	550	730	1,095	1,640	2,735
650	343	125	535	715	1,075	1,610	2,685
700	371	110	535	710	1,065	1,600	2,665
750	399	95	505	670	1,010	1,510	2,520
800	427	80	410	550	825	1,235	2,060
850	454	65	270	355	535	805	1,340
900	482	50	170	230	345	515	860
950	510	35	105	140	205	310	515
1000	538	20	50	70	105	155	260

For prolonged usage at temperatures above 800°F (427°C), consideration should be given to the possibility of graphite formation in Carbon Steel.

CAST STEEL GATE VALVES

CLASS 300



Figure No. Type of Ends
5206RF Flanged Raised Face

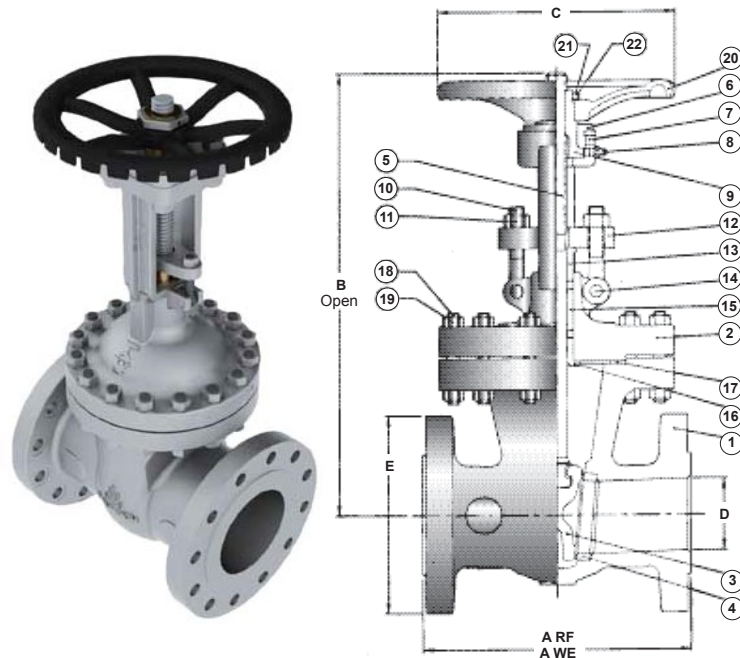

Standard Material Specifications

No.	Description	Materials
1	Body	ASTM A216 GR WCB
2	Bonnet	ASTM A216 GR WCB
3	Wedge Gate	ASTM A216 GR WCB + 13% Cr.
4	Seat Ring	ASTM A515 GR 70
5	Stem	ASTM A276 Type 410
6	Yoke	ASTM A216 GR WCB
7	Stem Nut Retainer	ASTM A36
8	Grease Fitting	Commercial Steel
9	Stem Nut	ASTM B 148 UNS C95600
10	Eyebolt	Alloy Steel
11	Eyebolt Nut	ASTM A307
12	Gland	ASTM A515 GR 70
13	Packing Bushing	ASTM A108 GR 1020
14	Eyebolt Pin	Alloy Steel
15	Stem Packing	Graphite
16	Bonnet Bushing	ASTM A276 Type 410
17	Bonnet Gasket	Spiral Stainless Steel 304/Graphite
18	Bonnet Stud	ASTM A193 GR B7
19	Bonnet Stud Nut	ASTM A194 GR 2H
20	Handwheel	ASTM A197
21	Handwheel Nut	ASTM A108 GR 1020
22	Set Screw	Alloy Steel
23	Retainer Bolt	Alloy Steel
24	Retainer Bolt Nut	ASTM A307
25	Yoke Stud	Alloy Steel
26	Yoke Stud Nut	ASTM A307
*27	Identification Plate	Stainless Steel

* Not Shown

*The above part lists're for size 8" up

Dimensions											
D Nominal Diameter	mm inch	50 2	65 2 1/2	80 3	100 4	150 6	200 8	250 10	300 12	350 14	400 16
A	mm.	215.9	241.3	282.5	304.8	403.2	419.1	457.2	501.65	762	838
B	mm.	473	568	546	673	935	1083	1314	1594	1730	1924
C	mm.	203.2	203.2	254	254	355.6	406.4	508	508	660	711
E	mm.	165.1	190.5	210	254	317.5	381	444.5	520.7	584	648
Weight	kg.	26	47	43	68	136	212	343	491.5	907	1202

Trim				
Trim		Internal Parts		
API	Walworth	Seat Ring	Gate (Disc)	Stem Hanger Pin Bonnet Bushing
8	*UT	Stellite No. 6	13% Cr. (SS 410)	13% Cr. (SS 410)
5	HF	Stellite No. 6	Stellite No. 6	13% Cr. (SS 410)

*UT-Trim (Universal Trim)

Test Pressures

For valves having flanges or butt welding ends to ANSI Class 300 Standards.

	shell Hydrostatic	Seat* Hydrostatic	Seat* Air under Water
lbf/in ²	1125	825	100
MPa	7.7	5.7	.7

*Seat leakage rate: All valves meet BS 6755 Part 1 leakage rate A (No visible leakage for duration of test).

Pressure - Temperature Ratings							
°F Temperature °C		MAXIMUM ALLOWABLE NON-SHOCK WORKING PRESSURE IN PSIG BY CLASS					
		150	300	400	600	900	1500
-20 to 100	-29 to 38	285	740	990	1,480	2,220	3,705
200	93	260	675	900	1,350	2,025	3,375
300	149	230	655	875	1,315	1,970	3,280
400	204	200	635	845	1,270	1,900	3,170
500	260	170	600	800	1,200	1,795	2,995
600	316	140	550	730	1,095	1,640	2,735
650	343	125	535	715	1,075	1,610	2,685
700	371	110	535	710	1,065	1,600	2,665
750	399	95	505	670	1,010	1,510	2,520
800	427	80	410	550	825	1,235	2,060
850	454	65	270	355	535	805	1,340
900	482	50	170	230	345	515	860
950	510	35	105	140	205	310	515
1000	538	20	50	70	105	155	260

For prolonged usage at temperatures above 800°F (427°C), consideration should be given to the possibility of graphite formation in Carbon Steel.

CAST STEEL GATE VALVES

CLASS 600

Figure No. Type of Ends
5232RF Flanged Raised Face

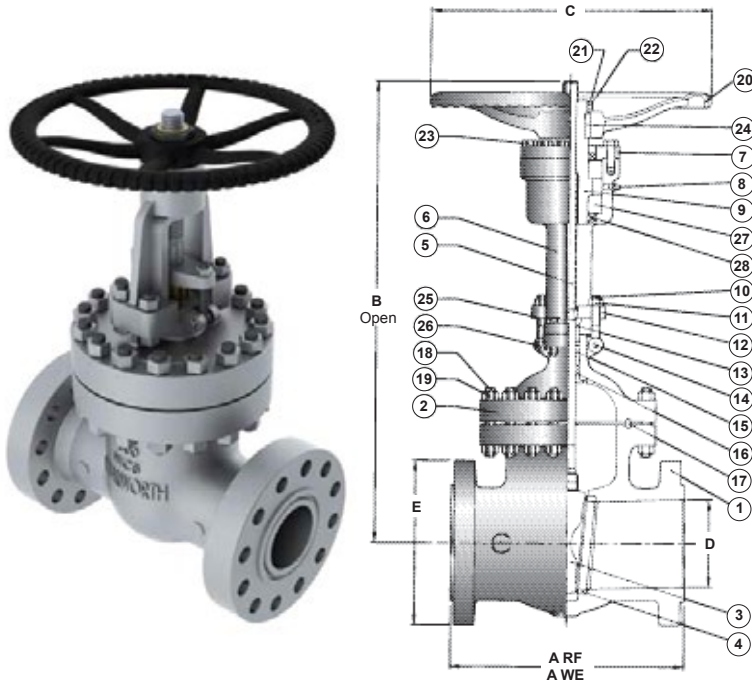

Standard Material Specifications

No.	Description	Materials
1	Body	ASTM A216 GR WCB
2	Bonnet	ASTM A216 GR WCB
3	Wedge Gate	ASTM A 216 GR WCB + 13% Cr.
4	Seat Ring	ASTMA 515 GR 70 + ST6
5	Stem	ASTM A276 Type 410
6	Yoke	ASTM A216 GR WCB
7	Stem Nut Retainer	ASTMA 36
8	Grease Fitting	Commercial Steel
9	Stem Nut	ASTM B 148 UNS C95600
10	Eyebolt	Alloy Steel
11	Eyebolt Nut	ASTMA 307
12	Gland Plate	ASTM A515 GR 70
13	Packing Bushing	ASTMA 108 GR 1020
14	Eye Lug Bolt	Alloy Steel
15	Stem Packing	Graphite
16	Bonnet Bushing	ASTM A 276 Type 410
17	Bonnet Gasket	ASTMA 108 GR 1010
18	Bonnet Stud	ASTMA 193 GR B7
19	Bonnet Stud Nut	ASTMA 194 GR 2H
20	Handwheel	ASTMA 197
21	Handwheel Nut	ASTMA 108 GR 1020
22	Set Screw	Alloy Steel
23	Retainer Cap Screw	Alloy Steel
24	Handwheel Key	Alloy Steel
25	Yoke Bolt	Alloy Steel
26	Yoke Bolt Nut	ASTMA 307
27	Stem Nut Bearing	Commercial Steel
28	Stem Nut Oil Seal	Rubber/Commercial Steel
*29	Identification Plate	Stainless Steel

* Not Shown

Dimensions

D Nominal Diameter	mm inch	50 2	65 2 1/2	80 3	100 4	150 6	200 8	250 10	300 12	350 14	400 16
A	mm.	292	330	356	432	559	660	787	838	889	991
B	mm.	527	592	622	811	1076	1291	1645	1900	1870	2032
C	mm.	178	203	254	406	457	508	660	660	762	762
E	mm.	165	191	205	273	356	419	508	559	603	686
Weight	kg.	41	52	74	141	312	538	884.5	1088.5	1500	1995

Trim

Trim		Internal Parts		
API	Walworth	Seat Ring	Gate (Disc)	Stem Hanger Pin Bonnet Bushing
8	*UT	Stellite No. 6	13% Cr. (SS 410)	13% Cr. (SS 410)
5	HF	Stellite No. 6	Stellite No. 6	13% Cr. (SS 410)

*UT-Trim (Universal Trim)

Test Pressures

For valves having flanges or butt welding ends to ANSI Class 600 Standards.

	shell Hydrostatic	Seat* Hydrostatic	Seat*Air under Water
lb/in ²	2250	1650	100
MPa	15.4	11.3	.7

*Seat leakage rate: All valves meet BS 6755 Part 1 leakage rate A (No visible leakage for duration of test).

Pressure - Temperature Ratings

°F Temperature °C		MAXIMUM ALLOWABLE NON-SHOCK WORKING PRESSURE IN PSIG BYCLASS					
		150	300	400	600	900	1500
-20 to 100	-29 to 38	285	740	990	1,480	2,220	3,705
200	93	260	675	900	1,350	2,025	3,375
300	149	230	655	875	1,315	1,970	3,280
400	204	200	635	845	1,270	1,900	3,170
500	260	170	600	800	1,200	1,795	2,995
600	316	140	550	730	1,095	1,640	2,735
650	343	125	535	715	1,075	1,610	2,685
700	371	110	535	710	1,065	1,600	2,665
750	399	95	505	670	1,010	1,510	2,520
800	427	80	410	550	825	1,235	2,060
850	454	65	270	355	535	805	1,340
900	482	50	170	230	345	515	860
950	510	35	105	140	205	310	515
1000	538	20	50	70	105	155	260

For prolonged usage at temperatures above 800°F (427°C), consideration should be given to the possibility of graphite formation in Carbon Steel.