



# Emech® Three-Way Temperature Control Valve

Steam-to-Water Mixing - E25S, E40S, and E50S



## Emech® Three-Way Temperature Control Valve

Emech® Three-Way Temperature Control Valve provides precise steam and water mixing to  $\pm 1^{\circ}\text{F}$  ( $0.5^{\circ}\text{C}$ ) over a  $32^{\circ}\text{F}$  -  $200^{\circ}\text{F}$  ( $0^{\circ}\text{C}$  -  $95^{\circ}\text{C}$ ) control range. The electronic actuator and temperature sensor ensure fast, accurate, and stable temperature control. The single compact assembly simplifies installation and the stand-alone unit provides a reliable solution for hot water supply in a range of industrial applications.

Even with sudden changes to inlet pressures and temperatures, the actuator aggressively responds to minimize outlet temperature variations, making the system ideal for use in industrial applications as a simple standalone mixing valve, or as an integrated mixing solution.

### General Features

- Top entry to valve allows inline access to internal parts
- 90° stroke time as low as 1.5 seconds for fast control action
- Precise positioning achieving 0.03° valve seat placement
- Keypad display for full actuator configuration without external devices required
- Local closed-loop temperature control
- Failsafe position feedback (non-contact absolute encoder)
- Manual override with electrical safety interlock
- 100% duty cycle rated for continuous control
- Electronic stroke setting (up to 355° rotation)



E25S



E50S

### Material and Design Specifications

Valve Body	Stainless Steel CF8M (Type 316)
Bonnet	
Disc	Nickle chrome and cobalt-coated stainless steel
Seal Material	Elastomer
Actuator Mounting	ISO 5211, 5210
End Connection	NPT (Flange available upon request)
Enclosure	NEMA 4X

### Technical Specifications

Operating Temperature	-13° - 257°F (-25°C - 125°C)
Operating Pressure	145 psi (10 bar)
Leakage Class	Class IV
Design	ASME B16.34
Operating Mode	<ul style="list-style-type: none"> <li>• Standalone control via onboard keypad</li> <li>• Analog (4-20mA input and output)</li> <li>• Modbus (RS-485 port)</li> </ul>

**SAFETY:** Consider the following situations during the design phase of the proposed circuit/system

- Sudden loss of water pressure
- Loss of power supply
- Over-temperature safety (fail-safe system)
- If cold water supply or temperature sensor fails, the valve will close in approximately two (2) seconds.
- In the event of a loss of power, the unit will remain in its last powered position and can be manually actuated using the manual override handle.





# Emech® Three-Way Temperature Control Valve

Steam-to-Water Mixing - E25S, E40S, and E50S

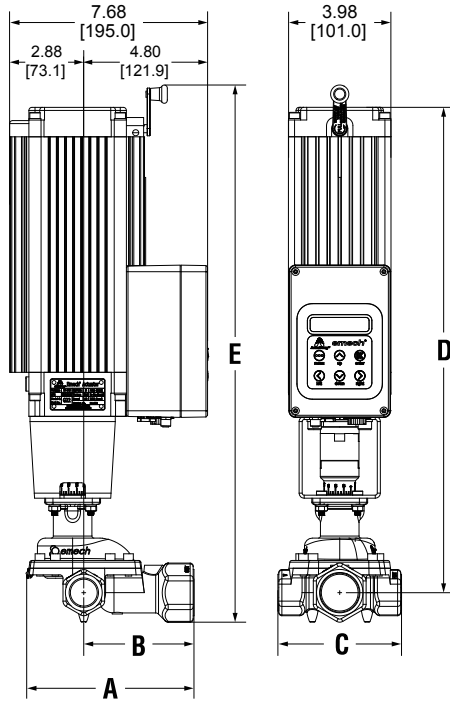

Dimensions - Threaded E25S and E40S

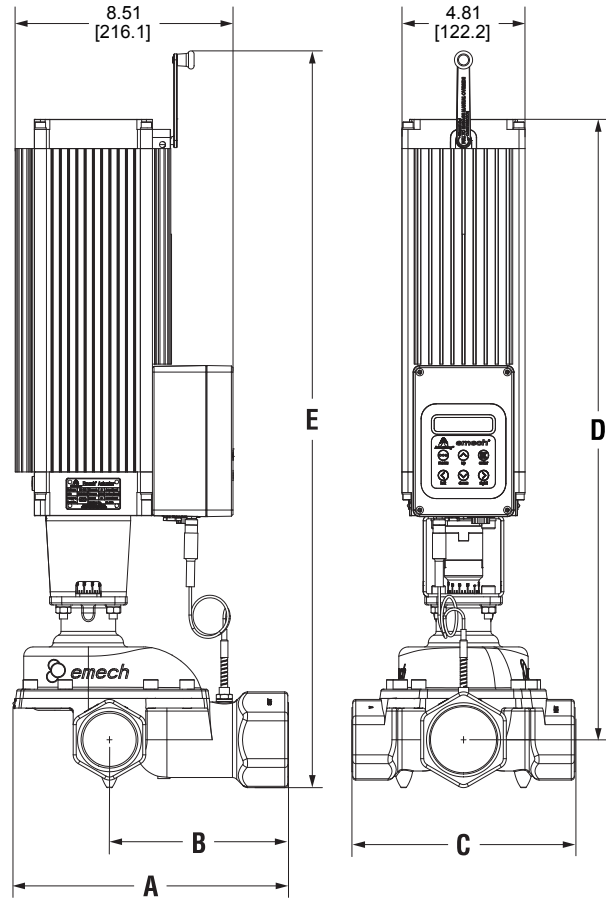

Dimensions - Threaded E50S

Dimensions					
Model	A	B	C	D	E
	in (mm)	in (mm)	in (mm)	in (mm)	in (mm)
E25S	6.42 (163.0)	4.28 (108.7)	4.72 (119.0)	19.69 (500.0)	18.82 (478.0)
E40S	7.83 (198.9)	5.06 (128.5)	6.77 (172.0)	20.86 (529.9)	20.00 (507.9)
E50S	10.74 (272.9)	7.08 (179.8)	8.66 (220.0)	24.24 (615.7)	28.50 (724.0)

Shipping Weights and Shipping Box Size					
Model	Length	Width	Height	Product Weight	Ship Weight
	in (mm)	in (mm)	in (mm)	lbs (kg)	lbs (kg)
E25S	21.50 (546.1)	14.25 (362.0)	9.25 (234.9)	22 (9.8)	47 (21.3)
E40S	23.00 (584.2)	14.25 (362.0)	13.25 (336.5)	27 (12.2)	53 (23.9)
E50S	28.00 (711.2)	16.00 (406.40)	14.50 (368.30)	55 (24.9)	100 (45.5)

**SIZING NOTE:** Refer to the Sizing Chart and Instructions on pages 9-11 in the Emech® F5 Manual (IOM-444) to select the appropriate model for your application.

**IMPORTANT NOTES:**

- Check valves **MUST** be installed on both inlets to the mixing system.
- Contact Armstrong or visit [armstronginternational.com](http://armstronginternational.com) for Emech® valve sizing program and application notes.

Further information on installation requirements and recommendations are available in the G2 Manual (IOM-458).