

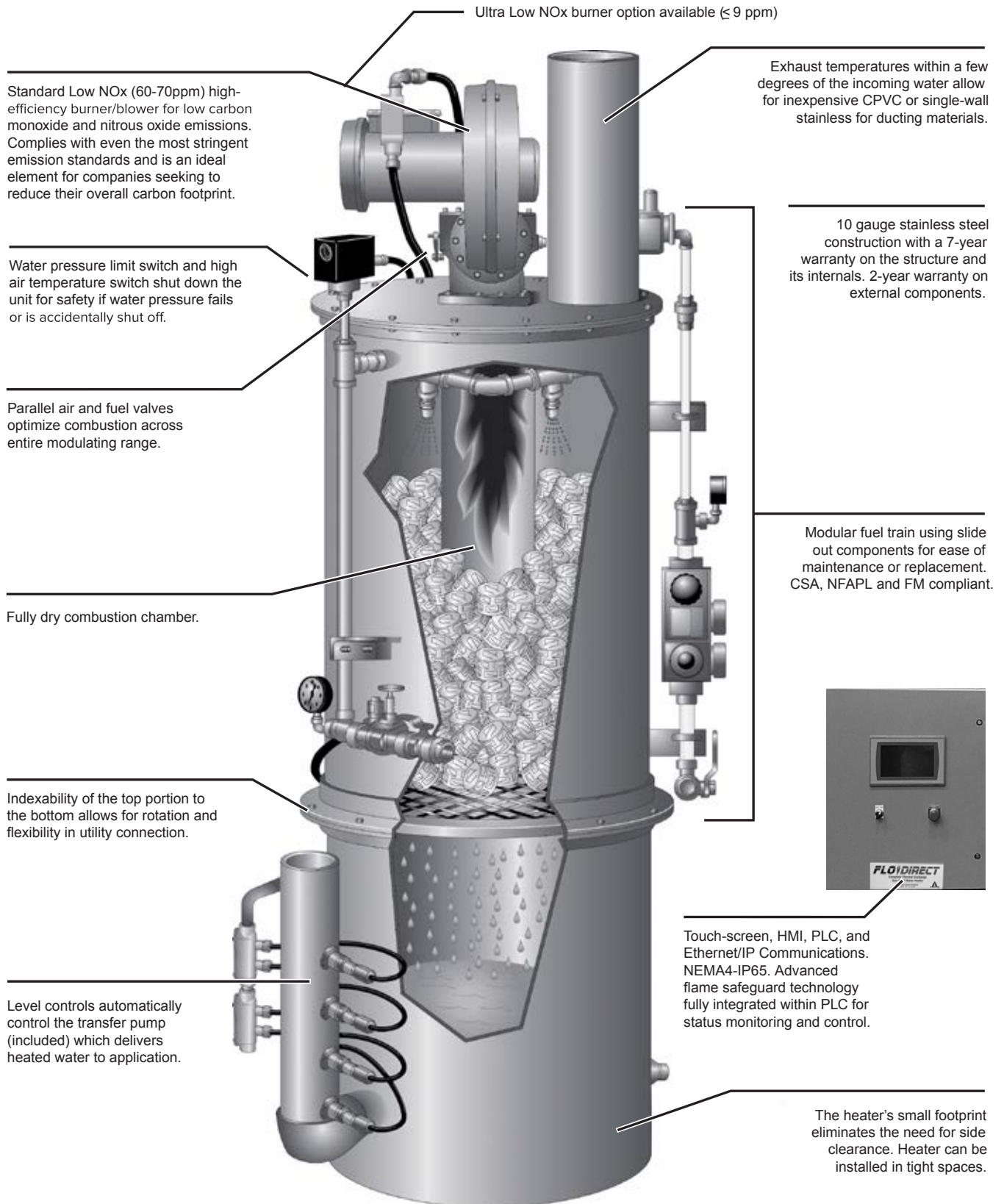

Flo-Direct®

Direct Gas-Fired Water Heater



For additional information, visit armstronginternational.com/products/flo-direct-gas-fired-water-heater/.





Flo-Direct®

Gas-Fired Water Heater



Armstrong Flo-Direct® gas-fired water heaters offer a complete range of high efficiency, compact, all stainless steel water heaters which are remarkably dependable, simple in design and operation, and suitable for a wide variety of hot water applications.

The Flo-Direct® gas-fired water heater can deliver fuel savings as high as 30-60% when compared to steam/water heating systems. Standard operating capacities are between 1 million and 10 million BTU per hour. Custom models with capacities up to 60 million BTU per hour are also available.

With a small footprint, 99.7% or greater high heat value (110% low heat value) heat transfer efficiencies*, remarkable dependability, ease of maintenance, and the ability to operate well with poor water quality, Armstrong Flo-Direct® gas-fired water heaters are the product of choice for companies seeking to achieve Energy Conservation Measure (ECM) and Reduced Carbon Footprint objectives.

Primary Markets include:

Food Process Industries

- Washdown
- Batch Production
- Vessel Filling
- Tank Cleaning
- Bottle Warming

Concrete Plants

- Preheated water for batch production

Building Heating

- Greenhouses
 - Recirculated hot water for general building heat
- Light Manufacturing/Warehouses
 - Recirculated hot water for general building heat
- Distillery Warehouses
- Aircraft Hangars

General Industry

- Boiler Make-Up Water

Customized hot water system solutions are our specialty. Multiple orientations, configurations and options are available.

The Armstrong Flo-Direct® can be provided with a variety of other equipment, including transfer pumps, storage tanks, variable frequency drive pump skids, downstream digital water temperature controls, and hose stations. Extensive customization is available to meet various application and engineering requirements, and factory testing is performed on all equipment.

Flo-Direct® Gas-Fired Water Heaters deliver unrivaled performance and efficiency

Incoming water is introduced into the top of the water heater through a series of calibrated dispersion nozzles. Cold water travels down through a bed of multifaceted stainless steel packing rings (pall rings) which break the water into smaller and smaller droplets.

A burner is mounted on top of the unit, firing downward through a centrally located flame tube. The flame tube is cooled by incoming cold water, and all of the fuel gases are consumed within this flame tube. The design allows all combustion to take place within a dry and cool environment, and produces very low levels of nitrous oxide (NO) and carbon monoxide (CO).

Heat from the flame enters the lower chamber from the bottom of the flame tube, and travels slowly upward through the packing rings. Efficient heat transfer occurs as the descending water comes in contact with the rising hot gases as both pass through the bed of packing rings in opposite directions.

This "rain" of hot water then falls into the lower chamber and is pumped out to a storage tank. Water temperatures up to 185°F (85°C) are available within two minutes after the unit starts.

The user programs the outlet water temperature on the heater's touchscreen interface.

The products of combustion are vented out of the top of the unit, and this exhaust is typically within a few degrees of incoming water temperature.

Features

- Meets multiple global water quality standards (Page 4)
- No internal moving parts
- Low-temperature exhaust
- 99.7% or greater high heat value efficiency
- Water treatment not required
- Stainless steel construction
- Takes up minimal floor space
- Seven year warranty on structure/two years on all other components

Engineered Solutions

Armstrong can provide integrated engineering, hot water systems with multiple water heaters, system pumps, and storage tanks. Controls are Ethernet-based and configured at the factory before shipping, allowing for plug-and-play integration onsite.





Flo-Direct®

Direct Gas-Fired Water Heater



Complete Thermal Exchange Technology

Developed from direct-contact water heating science, which was first introduced more than two decades ago, complete thermal exchange technology has revolutionized high-efficiency water heating methods. Today, the technology used in the Armstrong Flo-Direct® enjoys a proven record and has rapidly become the new standard in high-efficiency water heating and energy savings.

While traditional direct-contact water heating can offer significant energy savings when compared to a conventional steam boiler system, the Flo-Direct® direct gas-fired water heater offers an unparalleled 99.7% high heat value (110% approx. low heat value) efficiency rating* throughout each phase of its operation cycle.

The sustained operational efficiency of Armstrong Flo-Direct® direct gas-fired water heater creates the most energy efficient method of hot water production currently available.

No Scale Build-Up

The unique design of the Flo-Direct® direct gas-fired water heater prevents scale build-up because there are no "hot spots" internally or externally, and because calcium is prevented from completely falling out of suspension during operation. As a result, the mineral content of the influent water and the effluent water will be equal.

Armstrong Flo-Direct® achieves new standards for gas-fired water heaters

Older designs and traditional methods of direct-contact water heater technology could not provide the benefits of efficient thermal exchange. The technology in the Armstrong Flo-Direct® direct gas-fired water heater meets the following standards:

1. Flo-Direct® maintains a minimum of 99.7% high heat value (110% approx low heat value) efficiency in all modes of operation, not just under optimal conditions.
2. Flo-Direct® heaters have multiple thermal passes. Water and the combustion gases (or heat from the combustion) repeatedly come in contact. This ensures that the maximum amount of heat or energy from combustion is transferred to the water.
3. Flo-Direct® features a dry combustion chamber. This is vital to maintaining complete combustion at all times during operation.
4. Flo-Direct® units maintain complete combustion at all times.
5. Flo-Direct® units must have an integral water quality integrity system. Operational procedures must be in place to ensure that effluent water quality is equal to the influent water quality.

Complete combustion equals complete water quality

While many traditional methods of direct-contact water heating spray water directly on the flame (sometimes called "flame quenching", Flo-Direct®, using complete thermal exchange technology, avoids this process altogether. According to the Industrial Heating Equipment Association's Combustion Technology Manual, flame quenching promotes incomplete combustion, and produces alcohols, aldehyde, formic acid, higher order acids, carbon monoxide, as well as carbon dioxide and water vapor. Technology in the Armstrong Flo-Direct® maintains 99.7% high heat value* (110% approx. low heat value) combustion efficiency, while maintaining water quality at all times.

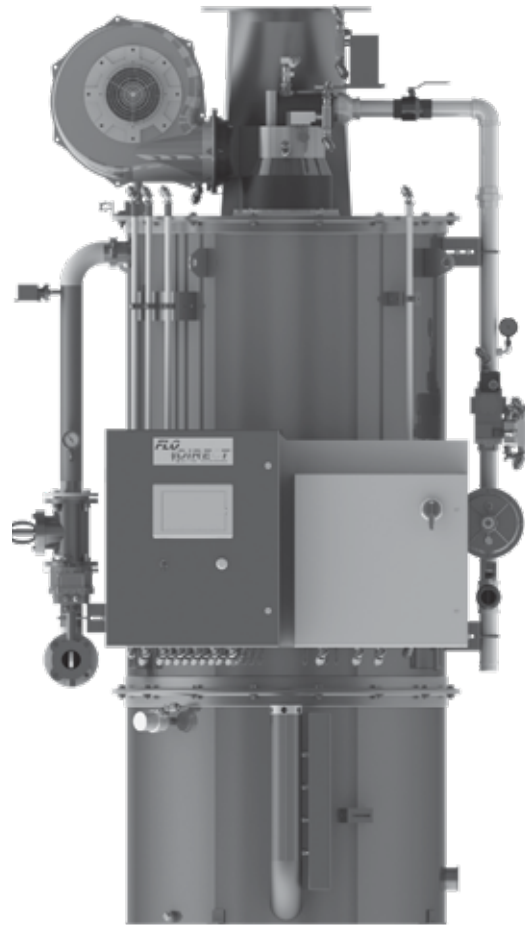

Global Water Quality Standards

Armstrong Flo-Direct® direct gas-fired water heating technology significantly limits the effluent water chemical additives typically attributed to other process water heating systems.

Our unique water heating process deaerates the water significantly. Independent third party testing has verified that this technology can actually remove some chemical constituents from the influent water.

NSF test results show that the effluent water from an Armstrong Flo-Direct® heater meets US, European Union and PRC bottled drinking water standards* and has been tested and documented as fully compliant with:

- USFDA - The United States Food and Drug Administration, Code of Federal Regulations Bottled Water Standard: Chapter I, Title 21, Part 165, Subpart B, Section 165.110.
- EU-TRW - The European Union Directives(s) - Treated Waters: 98/83/EC.
- People's Republic of China Standards for Drinking Water: GB5749-2006

* Statement presumes influent water also meets listed standards.





Flo-Direct®

Gas-Fired Water Heater



Specifications	
Gas Supply Pressure	2 - 6 psig / 0.14 - 0.41 barg
Dynamic Water Supply Pressure	Constant water pressure (+/-5 psi variation maximum) within a minimum of 30 psig/2 barg and a maximum of 100 psig/6.8 barg range is required for optimum performance
Maximum Inlet Water Temperature	100°F (38°C)
Minimum Inlet Water Temperature	32°F (0°C)
Maximum Effective Outlet Temperature	185°F (85°C)

Materials	
Upper and Lower Canister	Type 304 Stainless Steel #10 Glass Finish
Inlet Gas Train Piping	Malleable Iron with Standard Yellow Finish
Inlet Water Train Piping	Purge-Welded Stainless Steel
Spray Ring	Stainless Steel
Canister Gaskets	Warco White
Pall Rings	Type 304 Stainless Steel

Optional/Custom materials of construction available upon request.

Standard Sizing Formulas

$$\frac{\text{gpm} \times \Delta T}{2} = \text{AFD Model}$$

(AFD Model) x 2 = gpm

(AFD Model) x 2 = ΔT gpm

Standard Formula Key

gpm = Gallons per minute

ΔT = Temperature rise (°F)

AFD = Armstrong Flo-Direct® (e.g., 1000, 5000)

Metric Sizing Formulas

$$\frac{\text{lpm} \times \Delta T}{2} = \text{AFD Model}$$

(AFD Model) x 4.2 = lpm

(AFD Model) x 4.2 = ΔT lpm

Metric Formula Key

lpm = Liters per minute

ΔT = Temperature rise (°C)

AFD = Armstrong Flo-Direct® (e.g., 1000, 5000)

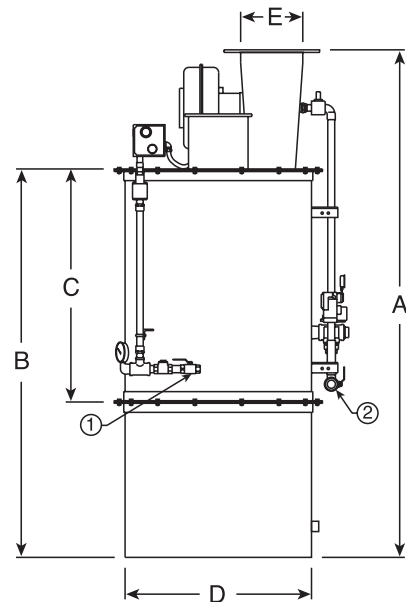

Flo-Direct® Dimensions and Weights

Model	Connections				Dimensions										Weight		BTU/hr
	1		2		A		B		C		D		E		lb	kg	
	in	mm	in	mm	in	mm	in	mm	in	mm	in	mm	in	mm			
1000	1	25	1	25	95	2413	71	1803	39	991	24	610	8	203	825	375	1,000,000
1500	1	25	1	25	97	2464	73	1854	41	1041	26	660	8	203	850	386	1,500,000
2000	1-1/2	40	1-1/2	40	100	2540	76	1930	44	1118	30	762	10-3/4	273	1500	680	2,000,000
3000	2	50	1-1/2	40	100	2540	76	1930	44	1118	36	914	12	305	1600	725	3,000,000
5000	2-1/2	65	2	50	127	3226	97	2464	65	1651	44	1118	16	406	2500	1136	5,000,000
6000	3	80	2	50	132	3353	100	2540	70	1778	47	1194	18	457	2900	1316	6,000,000
7000	3	80	2	50	139	3531	107	2718	77	1956	50	1270	18	457	3200	1455	7,000,000
9000	3	80	2	50	169	4293	139	3531	107	2718	60	1524	20	508	5000	2273	9,000,000
10000	3	80	2	50	181	4597	151	3835	119	3023	61	1549	20	508	5200	2405	10,000,000

Armstrong Flo-Direct® is available in capacities above 10,000,000 BTU/hr upon request



Armstrong Flo-Direct® gas-fired water heaters can be combined with other Armstrong equipment to deliver a wide variety of hot water solutions.

Non-Recirculating Hot Water Systems

Non-recirculating hot water systems are suitable for applications that experience frequent demand or processes that accommodate the evacuation of a dead-leg before receiving water that is heated to the set point temperature.

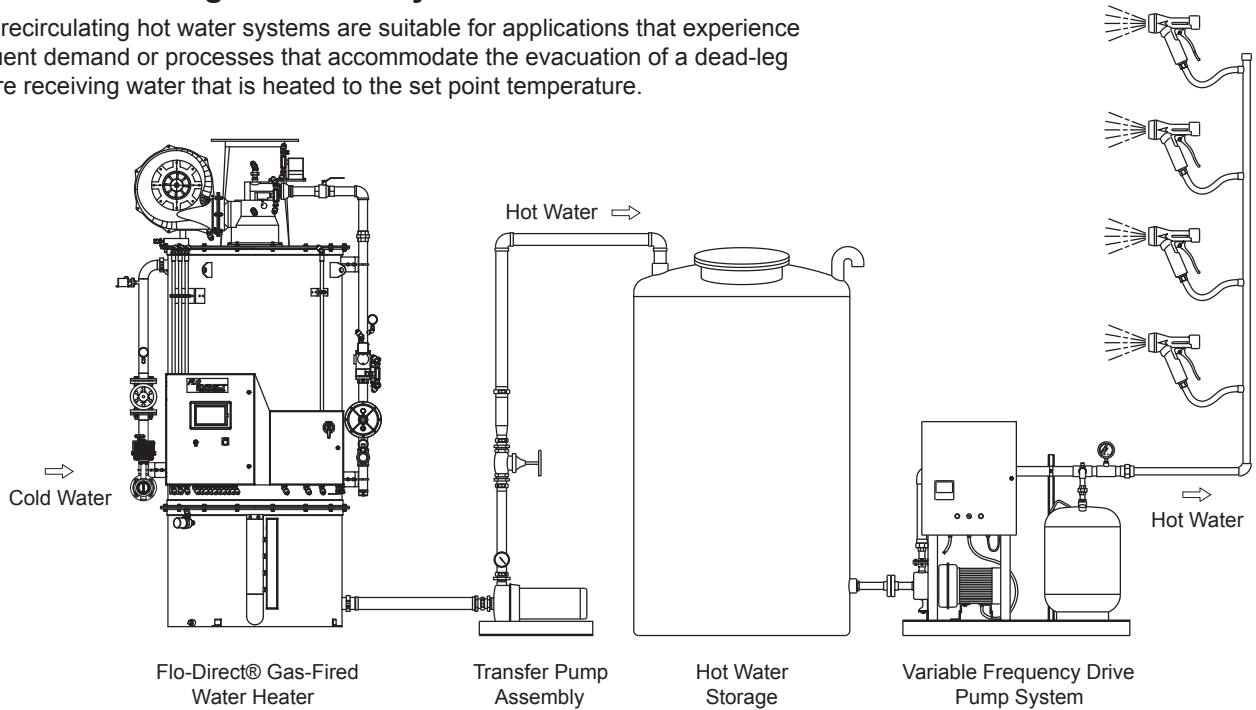

Recirculating Hot Water Systems

Recirculating hot water systems are suitable for installations which experience diverse draw-off or processes which cannot accommodate the evacuation of a dead-leg before receiving heater set point water temperatures.

Note: Recirculating hot water systems which idle at zero demand for long periods or experience a radiant heat loss during recirculation may require an immersion-type heater in the storage tank.

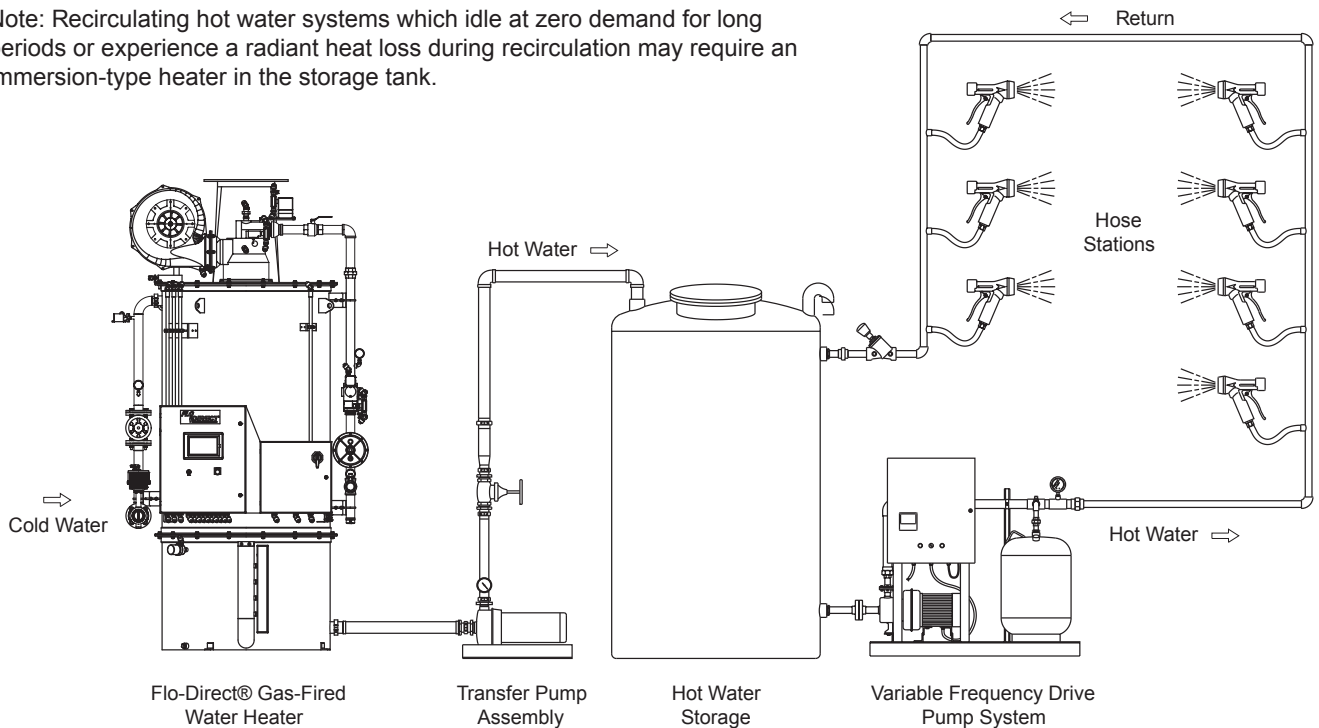



Multiple Temperature Hot Water Systems

Multiple temperature hot water systems can be designed as recirculating, non-recirculating or a combination of both. To achieve multiple temperatures for the same hot water system, Armstrong recommends one or more Emech® electronic water temperature controllers and Armstrong's hot and cold water hose stations.

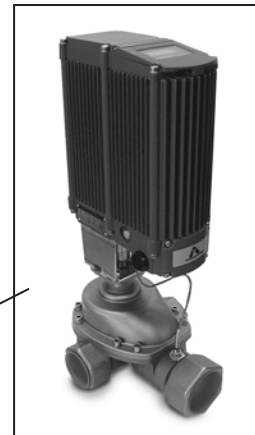

Emech® Water Temperature Controller

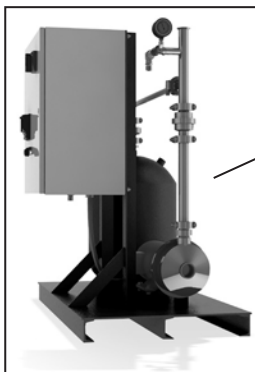
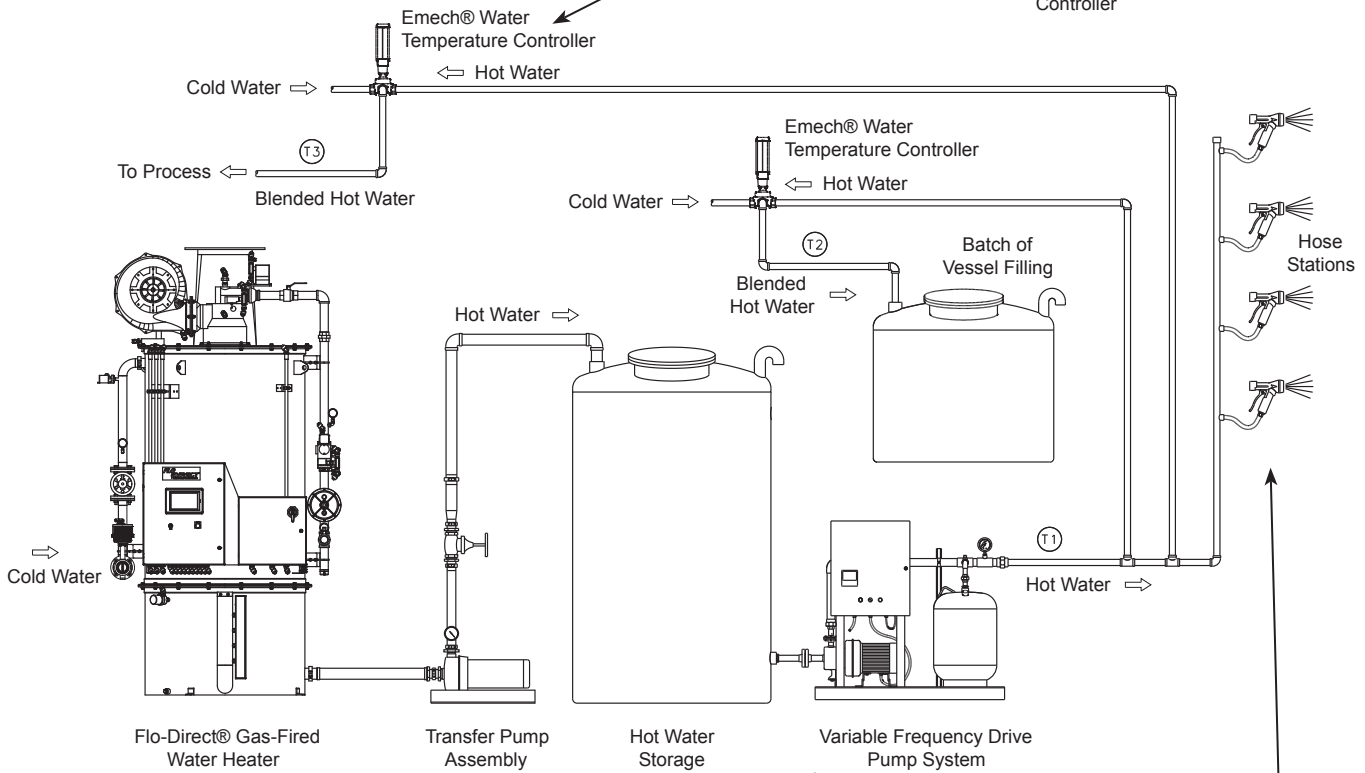

Armstrong Variable Frequency Drive Pump Assemblies

It is strongly recommended that the hot water storage temperatures are maintained at 140°F (60°C) or higher in accordance with US OSHA and CDC and corresponding global Legionella guidelines. If water temperatures below 140°F (60°C) are required, Armstrong offers a variety of supplemental thermostatic, electronic and digital water temperature controllers.

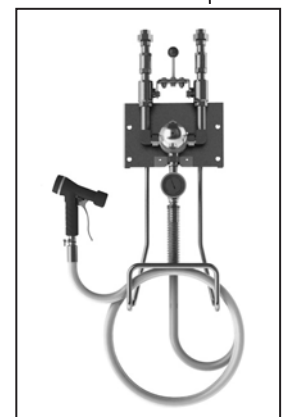

Armstrong Hot & Cold Water Hose Station