



814-816 Series Inverted Bucket Steam Trap

Cast Iron for Horizontal Installation



For Pressures to 250 psig (17 bar)...Capacities to 20,000 lb/hr (9,072 kg/hr)

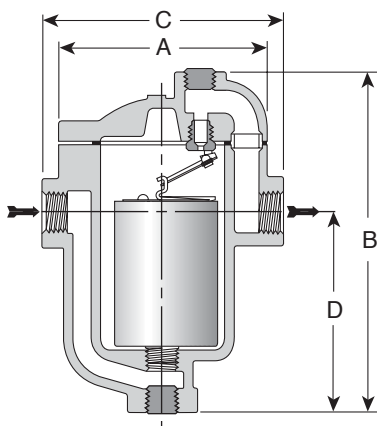

Description

The most reliable steam trap known—the inverted bucket—provides efficient condensate drainage of virtually all types of steam-using equipment. Put the inverted bucket to work in a tough cast iron package, and you have the best of both worlds. Because they operate efficiently for longer periods of time, Armstrong cast iron inverted buckets add solid energy savings to lower replacement/labor costs. All Armstrong cast iron inverted bucket steam traps are repairable for even bigger maintenance savings.

A unique leverage system multiplies the force provided by the bucket to open the valve against system pressure. The mechanism is free-floating, and has no fixed pivots to create wear or friction.

Because the mechanism is located at the top of the trap, no dirt can collect on the orifice. Small particles of dirt are held in suspension until discharged by the full differential purging action when the bucket sinks, pulling the valve off the seat.

The discharge orifice is surrounded by a water seal, preventing live steam loss. Automatic air venting is provided by a small vent hole in the bucket, which provides continuous automatic air and CO₂ venting at steam temperature.

Inverted bucket traps drain continuously, although discharging intermittently, allowing no condensate backup. They are also resistant to water hammer.

Maximum Operating Conditions

Maximum allowable pressure

(vessel design): 250 psig @ 450°F (17 bar @ 232°C)

Maximum operating pressure: Model 814-816: 250 psig (17 bar)

Connections

Screwed NPT (option BSPT)

Materials

Body: ASTM A48 Class 30
 Internals: All stainless steel—304
 Valve and seat: Hardened chrome steel—17-4PH
 Test plug: Carbon steel

Options

- Stainless steel internal check valve
- Thermic vent bucket
- Stainless steel pop drain
- Probe connection
- Thermo drain
- Scrub wire

Specification

Inverted bucket steam trap, type ... in cast iron, with continuous air venting at steam temperature, free-floating stainless steel mechanism, and discharge orifice at the top of the trap.

How to Order

Specify:

- Model number
- Size and type of pipe connection
- Maximum working pressure that will be encountered or orifice size
- Any options required

For a fully detailed certified drawing, refer to CD #1000.

814-816 Series Side Inlet, Side Outlet Traps. Add suffix "CV" to model number for internal check valve, "T" for thermic vent bucket.

Model No.	814		815		816	
	in	mm	in	mm	in	mm
Pipe Connections	1, 1-1/4	25, 32	1, 1-1/4, 1-1/2, 2	25, 32, 40, 50	2, 2-1/2	50, 65
Test Plug	1	25	1-1/2	40	2	50
"A" (Flange Diameter)	8	203	9	229	11-1/2	292
"B" (Height)	13-5/8	346	16-1/4	413	21-5/16	541
"C" (Face-to-Face)	9	229	10-1/4	260	13	330
"D" (Bottom to \varnothing Inlet)	7-13/16	198	8-1/16	205	11	279
Number of Bolts	8					
Weight lb (kg)	44 (20.0)		77 (32.2)		131 (59.4)	





814-816 Series Inverted Bucket Steam Trap

Cast Iron for Horizontal Installation



For Pressures to 250 psig (17 bar)...Capacities to 20,000 lb/hr (9,072 kg/hr)

