



1800 Series Inverted Bucket Steam Trap

All Stainless Steel for Horizontal Installation



For Pressures to 650 psig (45 bar)...Capacities to 1,802 lb/hr (817 kg/hr)

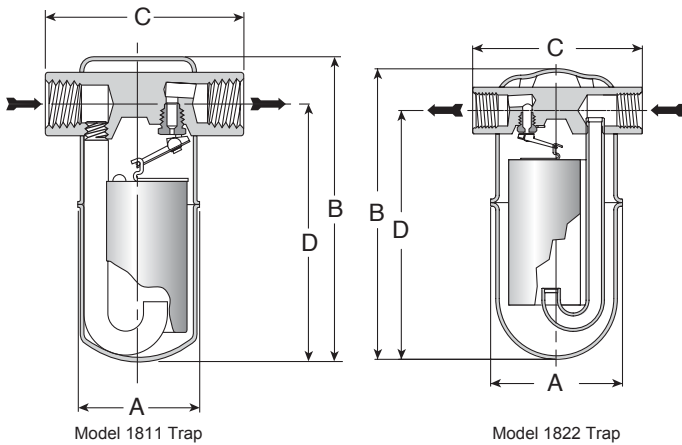

Description

A quick and easy "in-line" replacement for other types of side inlet/side outlet traps, the Armstrong 1800 Series brings together all the benefits of energyefficient inverted bucket operation. Side inlet/outlet all-welded construction means an inverted bucket trap that will operate efficiently on applications such as tracer lines, drips, heating, processing and similar applications.

With the 1800 Series you get freeze-resistant, all-stainless steel construction, with a three-year guarantee, plus all the benefits of inverted bucket operation:

Long, trouble-free service life

- Excellent purging action
- Continuous air venting
- Ease and flexibility of in-line installation

Maximum Operating Conditions

Maximum allowable pressure (vessel design):

Model 1810, 1811:	400 psig @ 800°F (28 bar @ 427°C)
Model 1822:	650 psig @ 600°F (45 bar @ 315°C)
	627 psig @ 700°F (43 bar @ 371°C)
	604 psig @ 800°F (41.6 bar @ 427°C)

Maximum operating pressure:

Model 1810:	200 psig (14 bar)
Model 1811:	400 psig (28 bar)
Model 1822:	650 psig (45 bar)

Connections

- Screwed NPT (option BSPT)
- Socket Weld (option)
- Flanged (option)

Materials

Body:	ASTM A240 Grade 304L
Internals:	All stainless steel—304
Valve and seat:	Hardened chrome steel—17-4PH or Titanium

Options

- Insu-Pak™ insulation for Models 1810/1811
- Stainless steel pop drain for Models 1811/1822
- Probe connection for Models 1811/1822
- Restricted orifice
- Wiggle wire

Specification

Inverted bucket steam trap, type ... in all stainless steel, freeze resistant, without gaskets, with continuous air venting at steam temperature, freefloating stainless steel mechanism, and orifice at the top of the trap.

How to Order

- Specify:
- Model number
 - Size and type of pipe connection
 - Maximum working pressure that will be encountered or orifice size
 - Any options required

For a fully detailed certified drawing, refer to CD #1005.

1800 Series Traps										
Model No.	1810		1811				1822			
	in	mm	in	mm	in	mm	in	mm	in	mm
Pipe Connections	3/8,1/2	10,15	1/2	15	3/4	20	1/2,3/4	15,20	1	25
"A" (Diameter)	2-11/16	68	2-11/16	68	2-11/16	68	3-7/8	99	3-7/8	99
"B" (Height)	5-5/16	135	6-5/16	160	6-9/16	167	8-1/2	218	8-1/2	218
"C" (Face to Face)	4-5/16	110	4-5/16	110	4-5/16	110	5	127	5	127
"D" (Bottom to ∇ Inlet)	4-7/16	113	5-7/16	138	5-9/16	141	7-3/8	187	7-1/8	181
Weight lb (kg)	1-3/4(0.8)		2(0.9)		2-3/8(1.1)		7(3)			



1800 Series Inverted Bucket Steam Trap

All Stainless Steel for Horizontal Installation



For Pressures to 650 psig (45 bar)...Capacities to 1,802 lb/hr (817 kg/hr)

Model 1810 Capacity

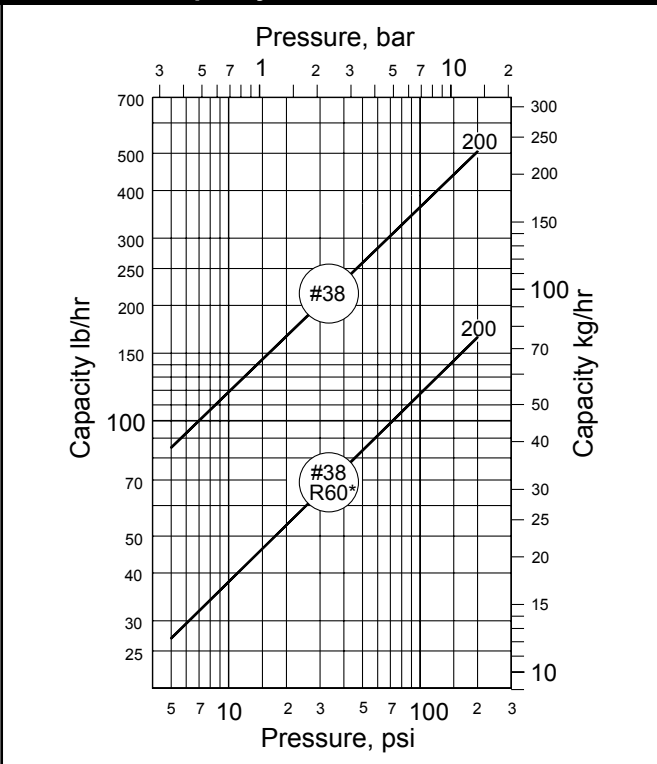

*NOTE: Because the orifice is located at the top, inverted bucket steam traps handle dirt and scale better than other types of traps. However, in applications where extremely dirty conditions exist, care should be exercised in the use of all types of restricted-orifice, reduced-capacity traps.

Model 1822 Capacity

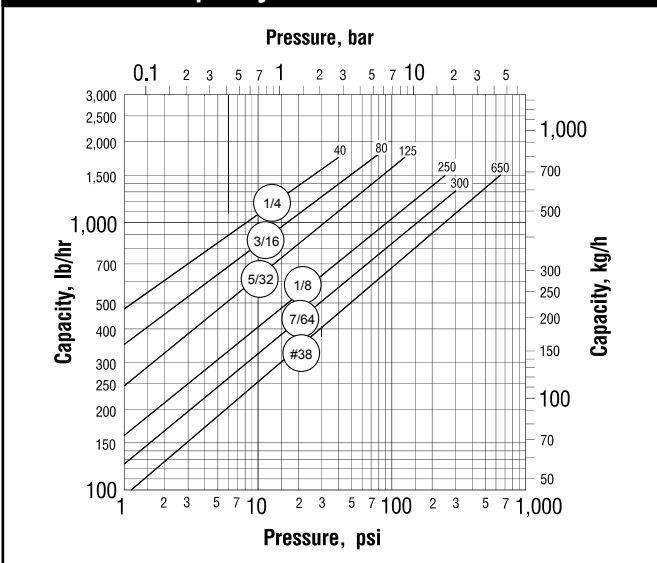

Model 1811 Capacity

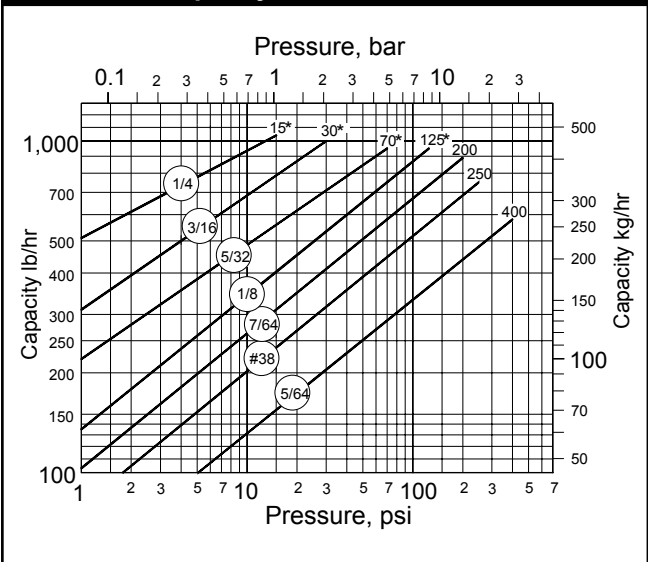

*Orifices available only with 3/4" connections.

Options

Pop Drain for Freeze Protection

In general, a properly selected and installed Armstrong trap will not freeze as long as steam is coming to the trap. If the steam supply is shut off, a pop drain should be used to automatically drain the trap. Stainless steel pop drain available for Models 1811 and 1822.

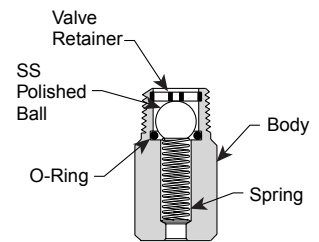

Maximum Operating Conditions

Pressure: 600 psig (41 bar)
Temperature: 350°F (177°C)

Insu-Pak™

Now you can insulate the in-line traps in your plant without complicating regular trap maintenance. Insu-Pak, a simple reusable insulation package, cuts the time and cost of in-field installation because it goes on in a snap. And it comes off just as easily. Insu-Pak can prevent trap freezeup when used with a properly designed condensate manifold. Designed for use with Model 1810 and Model 1811 traps.



Probe connections are available for trap monitoring on Models 1811 and 1822.