

Ball Valves Size 1/4" - 4" PN 100/PN 63/PN 40

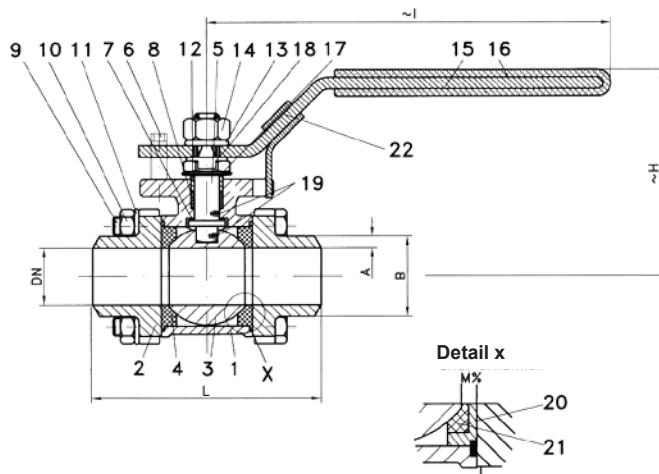

Ball valve with butt weld ends full bore, design acc. to KLINGER, material codes VIII and Xc face to face acc. to DIN 3202-S13

Specification

Three-piece ball valve with butt weld ends, face to face acc. to DIN3202-S13, full bore, blow-out-proof stem, body material stainless steel (ASTM A351-CF8M/ DIN1.4408) or steel (ASTMA216-WCB/GS-C25), free of non-ferrous metals, seat PTFE glassfibre reinforced, optional metal chamber plate, stem packing PTFE, disc spring loaded adjustable, top flange DIN EN ISO5211, approved by PED, TA-Luft certification (GERMAN clean air act) safety spring locking device is optional.

Proball KH 3T ball valves of all sizes are also available with pneumatical, electrical or hydraulic actuators.

Part Name	Material Code VIII	Material Code Xc
1. Body	1.0619	1.4408
2. Cap	1.0619	1.4408
3. Ball	1.4408	1.4408
4. Seat	PTFE gf	PTFE gf
5. Stem	1.4401	1.4401
6. Stopper	1.4301	1.4301
7. Thrust washer	PTFE gf	PTFE gf
8. Stem packing	PTFE	PTFE
9. Hex. screw	1.4301	1.4301
10. Hex. nut	1.4301	1.4301
11. Washer	1.4301	1.4301
12. Ring	1.4301	1.4301
13. Washer	1.4301	1.4301
14. Hex. nut	1.4301	1.4301
15. Handle	1.4301	1.4301
16. Insulation cover	Vinyl	Vinyl
17. Plate spring	1.4310	1.4310
18. Tap washer	1.4310	1.4301
19. Antistatic element	1.4401	1.4401
20. Chamber plate*	1.4301	1.4301
21. Seat*	PTFE gf	PTFE gf
22. Spring locking device*	1.4301	1.4301

*Special type

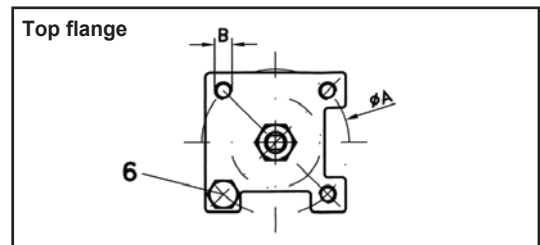

DN (mm)	ISO 5211	A	B
8+10	F03	36	M5
15+20	F04	42	M5
25+32+40	F05	50	M6
50+65	F07	70	M8
80+100	F10	102	M10

Dimension (mm)										
DN	DN	PN	Dimension (mm)					Kv-Value	Torque	Weight
mm	inch		A	B	H	I	L	m ³ /h	Nm	kg
8	1/4	100	2.75	13.5	59.7	118	70	6	3	0.4
10	3/8	100	3.6	17.2	59.7	118	70	7	3	0.4
15	1/2	100	3.15	21.3	61.7	135	75	10	5	0.6
20	3/4	100	3.45	26.9	68.4	135	90	25	10	0.8
25	1	63	4.35	33.7	76.2	167	100	35	11	1.2
32	1 1/4	63	5.2	42.4	82.4	167	110	46	20	1.9
40	1 1/2	63	4.15	48.3	98.9	203	125	80	26	2.6
50	2	63	5.15	60.3	109	216	150	110	30	4.2
65	2 1/2	40	5.55	76.1	152	278	190	310	70	9.8
80	3	40	4.45	88.9	159	374	220	360	90	14.3
100	4	40	7	114	189	374	270	820	120	25.0

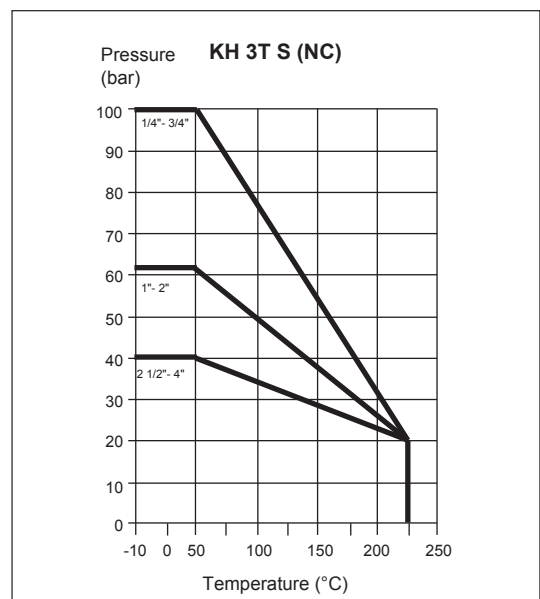

Ordering example:
KH 3T S (NC)-VIII, 2", PN 63
KH 3T S (NC)-Xc, 2", PN 63