

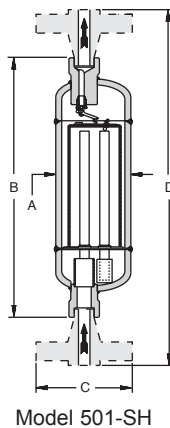

401-SH/501-SH Series Inverted Bucket Superheat Steam Trap Carbon Steel or Stainless Steel for Vertical Installation

For Pressures to 1,540 psig (105 bar)...Capacities to 950 lb/hr (432 kg/hr)

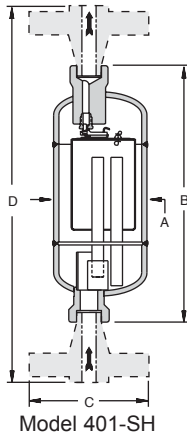

Description

Armstrong's 401-SH/501-SH Series inverted bucket steam trap line is made for overcoming the difficult combination of superheat and high pressure/low load service.

To survive this most severe steam service, Armstrong created an inverted bucket trap with a unique accumulation chamber. The chamber collects sufficient condensate to ensure full discharge cycles. A cup in the chamber floats up and down on the steam inlet tube, sealing it off as the condensate level rises. At the same time as the chamber collects condensate, steam continues to flow under the bucket, making sure that the discharge valve closes tightly until the condensate rises into the trap body and the bucket falls down. The operation is on/off, no throttling or dribbling.

Furthermore, it combines all the advantages of an inverted bucket steam trap:

- High resistance to wear, corrosion and water hammer with no gaskets.
- A unique leverage system multiplies the force provided by the bucket, to open the valve against system pressure.
- The mechanism is located at the top. No dirt can collect on the orifice. Small particles of dirt will be held in suspension until discharged by the full differential purging action.
- The discharge orifice is surrounded by a water seal, preventing live steam loss. Automatic air venting is provided by a small hole in the bucket.
- Inverted bucket traps require no adjustment. They do not allow condensate backup and are resistant to water hammer.

Maximum Operating Conditions

Maximum allowable pressure (vessel design):

- Model 401-SH: 1,000 psig @ 800°F (69 bar @ 427°C)
- Model 501-SH: 1,540 psig @ 850°F (105 bar @ 454°C)

Maximum operating pressure:

- Model 401-SH: 1,000 psig
- Model 501-SH: 1,540 psig

Connections

- Screwed NPT and BSPT (401-SH only)
- Socketweld
- Flanged

Materials

Body:

- Model 401-SH Carbon steel ASTM A106 Gr. B Sch. 80 pipe
- Model 501-SH Stainless steel 316L ASTM A312 Sch. 80 pipe

Internals: Stainless steel—304

Valve and seat: Titanium

Connections:

- Model 401-SH Stainless steel—304
- Model 501-SH Stainless steel—316L

Specification

Inverted bucket steam trap, type ... in carbon steel (stainless steel), with accumulation chamber, continuous air venting at steam temperature, stainless steel leverage system, with the discharge orifice at the top of the trap.

How to Order

Specify:

- Model number
- Size and type of pipe connection. When flanges are required, specify type of flange in detail
- Maximum working pressure that will be encountered or orifice size

For a fully detailed certified drawing, refer to:

401-SH CD #1011

501-SH CD #1012

401-SH and 501-SH Series Steam Traps						
Model No.	401-SH		501-SH			
	in	mm	in	mm	in	mm
Pipe Connections	1/2,3/4	15,20	1/2	15	3/4	20
"A" Diameter (NPT, BSPT or SW)	4	100	4	100	4	100
"B" Height (NPT, BSPT or SW)	11	275	13-9/16	344	13-9/16	344
"C" Diameter (Flanged)*	4-5/8	117	4-3/4	121	5-1/8	130
"D" Height (Flanged)*	15-1/8	384	18-3/16	462	18-11/16	475
Weight NPT, BSPT or SW lb (kg)	12 (5.5)		15 (7)			
Weight Flanged lb (kg)	15 (6.7)		29 (13)			

*401-SH 600 lb RF shown. 501-SH 900/1500 lb RF shown.

*last updated 11/15



401-SH/501-SH Series Inverted Bucket Superheat Steam Trap Carbon Steel or Stainless Steel for Vertical Installation

For Pressures to 1,540 psig (105 bar)...Capacities to 950 lb/hr (432 kg/hr)

Installation Recommendations

What little condensate there is on superheat and high pressure/low load service usually forms in drip legs and in the traps themselves. Therefore proper piping and drip legs of adequate size and diameter are essential for the successful operation of the Armstrong superheat trap.

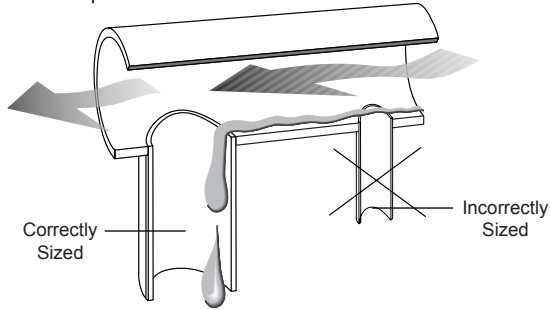

Drip Leg Sizing

The properly sized drip leg will capture condensate. Too small a drip leg can actually cause a venturi "piccolo" effect where pressure drop pulls condensate out of the drip leg and trap.

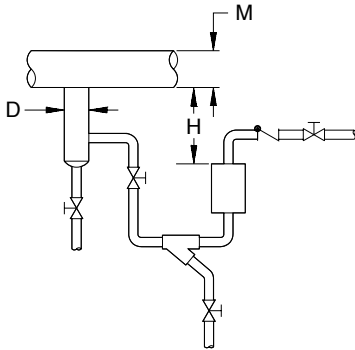

Trap Draining Drip Leg on Steam Main

KEY

□ Air □ Steam □ Condensate

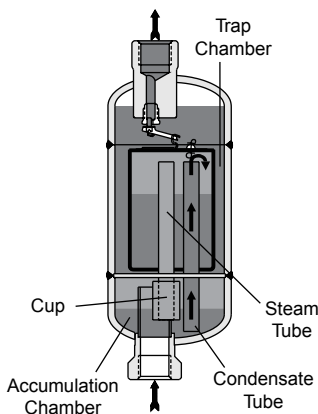

Cycling—Discharge Valve Wide Open

With the steam feed tube to the trap chamber sealed, condensate flows through the condensate feed tube (from accumulation chamber) into the trap chamber. This sinks the inverted bucket, which opens the discharge valve, cycling the trap.

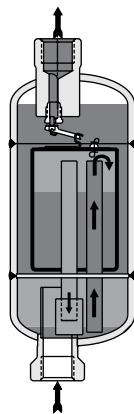

Cycle Ending

As the level of condensate in the accumulation chamber falls, the cup sealing the steam feed tube moves downward, opening a passage for steam to flow into trap chamber.

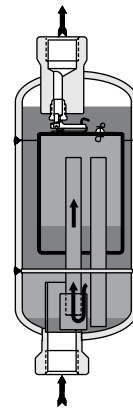

Trap Closed

As steam begins to flow through the accumulation chamber and up the steam feed tube under the inverted bucket in the trap chamber, the discharge valve closes tightly.

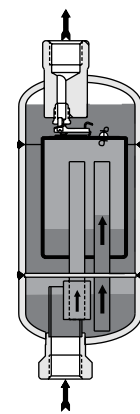

Cycle About to Repeat

As the level of condensate rises in the accumulation chamber, the cup floats up until it again seals the steam feed tube, and the cycle repeats.

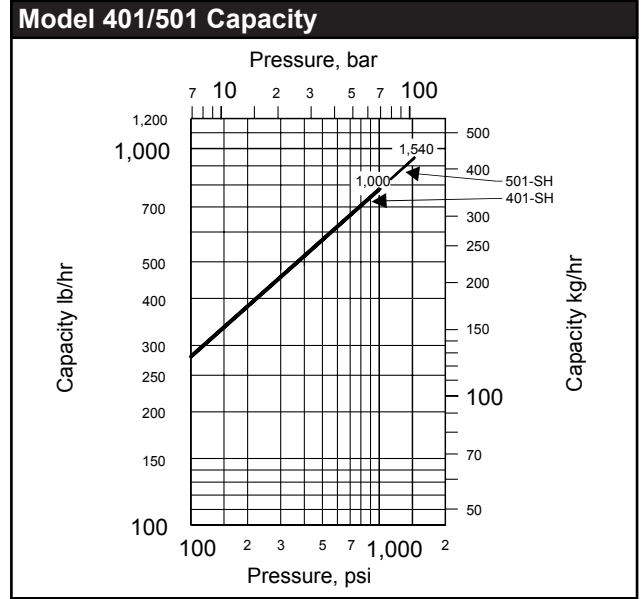

Recommended Steam Main and Branch Line Drip Leg Tracing							
M		D		H Drip Leg Length Minimum			
Steam Main Size		Drip Leg Diameter		Supervised Warm-Up		Automatic Warm-Up	
in	mm	in	mm	in	mm	in	mm
1/2	15	1/2	15	10	250	28	710
3/4	20	3/4	20	10	250	28	710
1	25	1	25	10	250	28	710
2	50	2	50	10	250	28	710
3	75	3	75	10	250	28	710
4	100	4	100	10	250	28	710
6	150	4	100	10	250	28	710
8	200	4	100	12	300	28	710
10	250	6	150	15	380	28	710
12	300	6	150	18	450	28	710
14	350	8	200	21	530	28	710
16	400	8	200	24	600	28	710
18	450	10	250	27	685	28	710
20	500	10	250	30	760	30	760
24	600	12	300	36	910	36	910

*last updated 11/15